

Panasonic®

Operating Instructions

Digital Video Cassette Recorder

DVCPRO 50

AJ-SD93_P

Model No. AJ-SD93_E

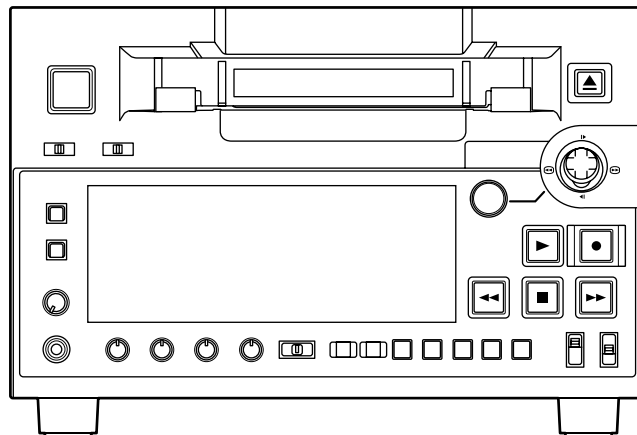

Before operating this product, please read the instructions carefully and save this manual for future use.

P **E**

Printed in Japan
VQT0L54-1

ENGLISH

S0704A1074 -M 

For AJ-SD93P

IMPORTANT

“Unauthorized recording of copyrighted television programmes, video tapes and other materials may infringe the right of copyright owners and be contrary to copyright laws.”



CAUTION: TO REDUCE THE RISK OF ELECTRIC SHOCK, DO NOT REMOVE COVER (OR BACK). NO USER-SERVICEABLE PARTS INSIDE. REFER SERVICING TO QUALIFIED SERVICE PERSONNEL.



The lightning flash with arrowhead symbol, within an equilateral triangle, is intended to alert the user to the presence of uninsulated “dangerous voltage” within the product’s enclosure that may be of sufficient magnitude to constitute a risk of electric shock to persons.



The exclamation point within an equilateral triangle is intended to alert the user to the presence of important operating and maintenance (servicing) instructions in the literature accompanying the appliance.

■ THIS APPARATUS MUST BE GROUNDED

To ensure safe operation the three-pin plug must be inserted only into a standard three-pin power outlet which is effectively grounded through normal household wiring.

Extension cords used with the equipment must be threecore and be correctly wired to provide connection to the ground. Incorrectly wired extension cords can be extremely hazardous.

The fact that the equipment operates satisfactorily does not imply that it is grounded, and the installation is not necessarily safe. For your safety, if in any doubt about the effective grounding of the equipment or power outlet, please consult a qualified electrician.

CAUTION:

TO COMPLETELY DISCONNECT THIS APPARATUS FROM THE AC MAINS, DISCONNECT THE POWER SUPPLY CORD PLUG FROM THE AC RECEPTACLE. THE AC OUTLET (MAIN SOCKET) SHALL BE INSTALLED NEAR THE EQUIPMENT AND SHALL BE EASILY ACCESSIBLE.

WARNING:

TO REDUCE THE RISK OF FIRE OR SHOCK HAZARD, DO NOT EXPOSE THIS EQUIPMENT TO RAIN OR MOISTURE. TO REDUCE THE RISK OF FIRE OR SHOCK HAZARD, KEEP THIS EQUIPMENT AWAY FROM ALL LIQUIDS-USE AND STORE ONLY IN LOCATIONS WHICH ARE NOT EXPOSED TO THE RISK OF DRIPPING OR SPLASHING LIQUIDS, AND DO NOT PLACE ANY LIQUID CONTAINERS ON TOP OF THE EQUIPMENT.

CAUTION:

Do not install or place this deck in a bookcase, built-in cabinet or any other confined space in order to maintain adequate ventilation. Ensure that curtains and any other materials do not obstruct the ventilation to prevent risk of electric shock or fire hazard due to overheating.

CAUTION:

TO REDUCE THE RISK OF FIRE OR SHOCK HAZARD AND ANNOYING INTERFERENCE, USE THE RECOMMENDED ACCESSORIES ONLY.

CAUTION:

TO REDUCE THE RISK OF FIRE OR SHOCK HAZARD, REFER MOUNTING OF THE OPTIONAL INTERFACE BOARD TO QUALIFIED SERVICE PERSONNEL.

CAUTION:

TO REDUCE THE RISK OF FIRE OR SHOCK HAZARD, REFER CHANGE OF SWITCH SETTING INSIDE THE DECK TO QUALIFIED SERVICE PERSONNEL.

FCC Note:

This equipment has been tested and found to comply with the limits for a class A digital device, pursuant to Part 15 of the FCC Rules. These limits are designed to provide reasonable protection against harmful interference when the equipment is operated in a commercial environment. This equipment generates, uses, and can radiate radio frequency energy and, if not installed and used in accordance with the instruction manual, may cause harmful interference to radio communications. Operation of this equipment in a residential area is likely to cause harmful interference in which case the user will be required to correct the interference at his own expense.

Warning: To assure continued FCC emission limit compliance, the user must use only shielded interface cables when connecting to external units. Also any unauthorized changes or modifications to this equipment could void the user’s authority to operate it.

CAUTION:

This apparatus can be operated at a voltage in the range of 100 – 240 V AC. Voltage other than 120 V is not intended for U.S.A. and Canada.

CAUTION:

Operation at a voltage other than 120 V AC may require the use of a different AC plug. Please contact either a local or foreign Panasonic authorized service center for assistance in selecting an alternate AC plug.

CAUTION:

Even when the Power Switch is in the OFF position, a small current flows the filter circuit.

Caution for AC Mains Lead

FOR YOUR SAFETY PLEASE READ THE FOLLOWING TEXT CAREFULLY.

This product is equipped with 2 types of AC mains cable. One is for continental Europe, etc. and the other one is only for U.K.

Appropriate mains cable must be used in each local area, since the other type of mains cable is not suitable.

FOR CONTINENTAL EUROPE, ETC.

Not to be used in the U.K.

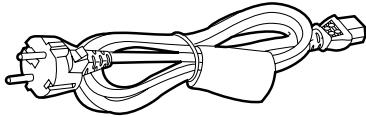

FOR U.K. ONLY

If the plug supplied is not suitable for your socket outlet, it should be cut off and appropriate one fitted.

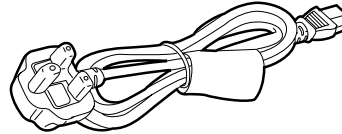

FOR U.K. ONLY

This appliance is supplied with a moulded three pin mains plug for your safety and convenience.

A 13 amp fuse is fitted in this plug.

Should the fuse need to be replaced please ensure that the replacement fuse has a rating of 13 amps and that it is approved by ASTA or BSI to BS1362.

Check for the ASTA mark  or the BSI mark  on the body of the fuse.

If the plug contains a removable fuse cover you must ensure that it is refitted when the fuse is replaced.

If you lose the fuse cover the plug must not be used until a replacement cover is obtained.

A replacement fuse cover can be purchased from your local Panasonic Dealer.

IF THE FITTED MOULDED PLUG IS UNSUITABLE FOR THE SOCKET OUTLET IN YOUR HOME THEN THE FUSE SHOULD BE REMOVED AND THE PLUG CUT OFF AND DISPOSED OF SAFELY. THERE IS A DANGER OF SEVERE ELECTRICAL SHOCK IF THE CUT OFF PLUG IS INSERTED INTO ANY 13 AMP SOCKET.

If a new plug is to be fitted please observe the wiring code as shown below.

If in any doubt please consult a qualified electrician.

WARNING: THIS APPLIANCE MUST BE EARTHED.

IMPORTANT: The wires in this mains lead are coloured in accordance with the following code:

- | | |
|-------------------|---------|
| Green-and-Yellow: | Earth |
| Blue: | Neutral |
| Brown: | Live |

As the colours of the wires in the mains lead of this appliance may not correspond with the coloured markings identifying the terminals in your plug, proceed as follows:

- The wire which is coloured GREEN-AND-YELLOW must be connected to the terminal in the plug which is marked with the letter E or by the Earth symbol  or coloured GREEN or GREEN-AND-YELLOW.
- The wire which is coloured BLUE must be connected to the terminal in the plug which is marked with the letter N or coloured BLACK.
- The wire which is coloured BROWN must be connected to the terminal in the plug which is marked with the letter L or coloured RED.

How to replace the fuse

1. Open the fuse compartment with a screwdriver.

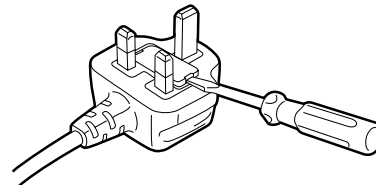

2. Replace the fuse.

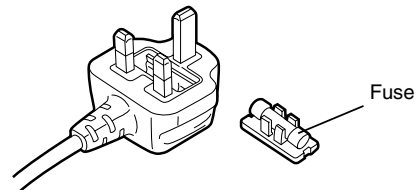

For AJ-SD93E

IMPORTANT

“Unauthorized recording of copyrighted television programmes, video tapes and other materials may infringe the right of copyright owners and be contrary to copyright laws.”

Operating precaution

Operation near any appliance which generates strong magnetic fields may give rise to noise in the video and audio signals. If this should be the case, deal with the situation by, for instance, moving the source of the magnetic fields away from the unit before operation.

■ THIS APPARATUS MUST BE EARTHED

To ensure safe operation the three-pin plug must be inserted only into a standard three-pin power point which is effectively earthed through the normal household wiring.

Extension cords used with the equipment must be three-core and be correctly wired to provide connection to earth. Wrongly wired extension cords are a major cause of fatalities.

The fact that the equipment operates satisfactorily does not imply that the power point is earthed and that the installation is completely safe. For your safety, if in any doubt about the effective earthing of the power point, consult a qualified electrician.

■ DO NOT REMOVE PANEL COVER BY UNSCREWING.

To reduce the risk of electric shock, do not remove cover. No user serviceable parts inside.

Refer servicing to qualified service personnel.

CAUTION:

TO COMPLETELY DISCONNECT THIS APPARATUS FROM THE AC MAINS, DISCONNECT THE POWER SUPPLY CORD PLUG FROM THE AC RECEPTACLE. THE AC OUTLET (MAIN SOCKET) SHALL BE INSTALLED NEAR THE EQUIPMENT AND SHALL BE EASILY ACCESSIBLE.

WARNING:

TO REDUCE THE RISK OF FIRE OR SHOCK HAZARD, KEEP THIS EQUIPMENT AWAY FROM ALL LIQUIDS-USE AND STORE ONLY IN LOCATIONS WHICH ARE NOT EXPOSED TO THE RISK OF DRIPPING OR SPLASHING LIQUIDS, AND DO NOT PLACE ANY LIQUID CONTAINERS ON TOP OF THE EQUIPMENT.

CAUTION:

TO REDUCE THE RISK OF FIRE OR SHOCK HAZARD AND ANNOYING INTERFERENCE, USE THE RECOMMENDED ACCESSORIES ONLY.

CAUTION:

TO REDUCE THE RISK OF FIRE OR SHOCK HAZARD, REFER MOUNTING OF THE OPTIONAL INTERFACE BOARD TO AUTHORIZED SERVICE PERSONNEL.

CAUTION:

TO REDUCE THE RISK OF FIRE OR SHOCK HAZARD, REFER CHANGE OF SWITCH SETTING INSIDE THE DECK TO QUALIFIED SERVICE PERSONNEL.

CAUTION:

Do not install or place this deck in a bookcase, built-in cabinet or any other confined space in order to maintain adequate ventilation. Ensure that curtains and any other materials do not obstruct the ventilation to prevent risk of electric shock or fire hazard due to overheating.

CAUTION:

Even when the Power Switch is in the OFF position, a small current flows the filter circuit.

Contents

Introduction	6
Included accessories	6
Optional boards	6
Features	7
Parts and their functions	8
• Front Panel	8
• Display Panel	11
• Rear Panel	12
Tapes	13
IEEE 1394 digital interface.....	14
Joystick.....	15
PF (Programmable Function).....	15
• Registering the items in the PF buttons.....	15
• Performing operations using the PF buttons....	15
Repeat playback.....	16
Setup (initial settings).....	17
Setup menus.....	18
• SYSTEM menu	20
• USER menus	21
<BASIC>	21
<OPERATION>.....	23
<INTERFACE>	24
<TAPE PROTECT>	25
<TIME CODE>.....	26
<VIDEO>.....	28
<AUDIO>	30
<V BLANK>.....	32
<DIF>	33
<MENU>	34
Time code/user bit.....	35
Superimpose screen	36
Video head cleaning.....	37
Condensation	37
Maintenance.....	37
Error messages	38
Specifications	43

Introduction

The model AJ-SD93 multi-purpose digital VTR uses small, 1/4-inch wide cassette tapes to record and play back images with a high picture quality at a video recording rate of 50 Mbps while it can also record and play back DVCPRO (25 Mbps) format tapes as well as play back consumer-use DV/DVCAM tapes.

It comes with the following features.

- This high-picture-quality VTR incorporates digital compression technology to dramatically reduce the deterioration of the picture quality and sound quality resulting from dubbing.
- It is equipped with an IEEE 1394 interface as a standard feature and, in compliance with the IEEE 1394 standard, it can digitally transmit video and audio signals as well as time code signals to a digital VTR, etc.

- It has a compact and lightweight design so that it can readily be carried around or easily installed in a rack.

Included accessories

- 3-pin power cord x 1

Optional boards

- **Analog interface board:**
AJ-YA93P
- **SDI interface board:**
AJ-YA94G

Use only the optional boards listed above.

Features

■ Compact and lightweight

This unit is a DVCPRO50 digital VTR which uses 1/4-inch wide cassette tapes. Its compact and lightweight design makes it ideal as a feeder for non-linear editing or as a viewer installed on a desk-top, for instance.

■ Up to 92 minutes of recording

M cassettes (max. 33 minutes: using the AJ-5P33MP) and L cassettes (max. 92 minutes: using the AJ-5P92LP) can be used with this unit. Tape width is a compact 1/4-inch.

■ Superior picture quality

Superior picture quality is achieved through 4:2:2 component signal recording at 2 times the recording rate of the DVCPRO format.

■ 4-channel, high-sound-quality digital audio

The unit can record and play back 4-channel PCM audio. (However, it does not support cue recording or playback.)

■ IEEE 1394 digital input/output

The IEEE 1394 digital interface, which is provided as a standard feature, enables DVCPRO50 or DVCPRO/DV compressed digital video and audio signals to be input and output with no accompanying deterioration of the picture quality.

■ Compatibility with DVCPRO (25 Mbps) format

This unit can record, play back and edit material in the DVCPRO (25 Mbps) format.

■ Compatibility with general consumer video equipment

DV cassette tapes containing material shot with a consumer digital camera or the like can be played back on this unit. A cassette adapter (AJ-CS455P) is necessary when a mini DV cassette tape is to be used.

■ Digital slow motion

Panasonic's original digital slow-motion technology makes it possible to obtain clear pictures even during slow playback at speeds ranging from -0.43x to +0.43x. (DVCPRO, DVCPRO50 only)

■ Joystick

The unit comes with a joystick (stick controller). It is used to control variable-speed playback during searches, etc.

In addition, the settings for the on-screen menus and time code generator can also be accomplished easily using the joystick.

■ PF (Programmable Function) buttons

The unit comes with three PF buttons. Any three frequently used setup menus can be selected, and by operating these buttons on the front panel, it is possible to change the menu settings.

■ Recording and playback of UMID information

Recording and playback of UMID (Unique Material Identifier) information complies with the SMPTE 330M standard.

UMID information can be checked on the DIAG menu.

UMID information cannot be played back correctly by VTRs that do not support the recording and playback of UMID information. In addition, even if a VTR that does not support the recording and playback of UMID information is connected to this unit and recording performed, UMID information will not be recorded correctly.

■ Time code

The unit incorporates a TCG (time code generator)/TCR (time code reader). In addition to the internal time code, use of the analog interface board (option: AJ-YA93P) enables the external time code input or input signal VITC to be recorded on the unit as the time code.

■ Multi-functional interfaces

• Serial digital input/output

Use of the SDI interface board (option: AJ-YA94G) enables interfacing of the serial digital component signals.

• Analog video/audio input/output

Use of the analog interface board (option: AJ-YA93P) enables the following signals :

- Composite video input/output
- Component video input/output
- Reference video input (BNC, input x1; loop-through x1)
- Analog audio input/output
Input: XLR, 4 channels; output: XLR, 4 channels
- Time code input/output (BNC connectors, 1 each for input, output)
- 9-pin control input (RS-422)

■ Menu-based setup

The setup settings, which are conducted prior to operating the unit, are performed while viewing the setup menus on the unit's display or a TV monitor.

Parts and their functions

Front panel

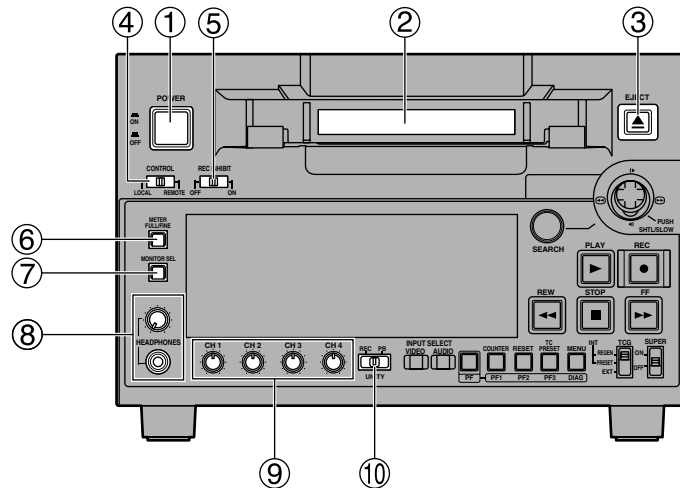

① POWER switch

② Cassette insertion slot

③ EJECT button

When this button is pressed, the tape is unloaded and the cassette is ejected automatically a few seconds later.

When CTL display has been selected for the counter display, the display is reset.

EJECT button operation can be enabled or disabled with setup menu No. 115 (EJECT SW INH).

④ CONTROL switch

This is selected to control the unit from an external source using the REMOTE connector.

REMOTE: Set to this position to control the unit using the 9-pin REMOTE connector and IEEE 1394 AV/C commands.

LOCAL : Set to this position to control the unit using the controls on the unit's operation panel.

⑤ REC INHIBIT switch

This switch is used to enable or disable recording on the cassette tape.

ON:

Recording on the cassette tape is disabled (inhibited).

In this state, the REC INH lamp lights on the display panel.

OFF:

Recording on the cassette tape is enabled so long as the accidental erasure prevention mechanism on the cassette tape is set to enable recording.

⑥ METER (FULL/FINE) selector button

This button is used to select the scale display for the audio level meter.

FULL mode : The standard scale ($-\infty$ to 0 dB) is selected.

FINE mode : The scale in 0.5 dB increments is selected. The  position indicates the standard level of -20 dB (-18 dB). (See page 11)

⑦ MONITOR SEL button

This button is used to select the audio signals which are to be output to the AUDIO MON L and R connectors.

Each time the button is pressed, the audio signals to be output to the AUDIO MON L or R connector are changed in the following sequence.

L : [CH1] → [CH3] → [CH1] → [CH2] → [CH3] → [CH4]
 R : [CH2] → [CH4] → [CH1] → [CH2] → [CH3] → [CH4]
 → [CH1+CH2] → [CH3+CH4]
 → [CH1+CH2] → [CH3+CH4]

Which signal is currently selected is displayed by the lighting of the L or R lamp on the level meter display.

⑧ Headphone jack and volume control

When stereo headphones are connected to the headphone jack, the sound can be monitored using the headphones during recording or playback.

⑨ Audio level control knobs

These knobs are used to adjust the recording and playback level of the PCM audio signals (CH1, CH2, CH3 and CH4).

Whether the recording level or playback level is to be adjusted is selected using the audio level control selector switch ⑩.

Note:

The level of the IEEE 1394 digital input/output audio signals cannot be adjusted.

⑩ Audio level control selector switch

UNITY: At this position, the audio signals are recorded or played back at a fixed level regardless of the position of the audio level control knobs ⑨.

REC : At this position, the audio signals are recorded at the level which has been adjusted by the audio level control knobs ⑨.

PB : At this position, the audio signals are played back at the level which has been adjusted by the audio level control knobs ⑨.

Note:

It is not possible to set this switch so that both the recording level and playback level can be adjusted.

When REC is selected, UNITY (fixed level) is set for the playback level; when PB is selected, UNITY is set for the recording level.

Parts and their functions (continued)

Front panel

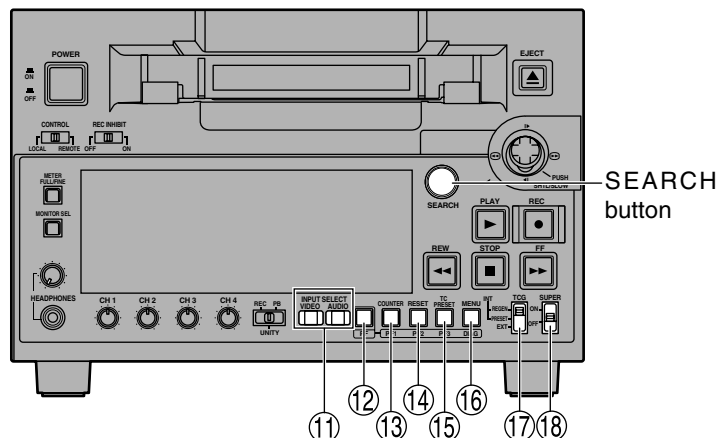

⑪ INPUT SELECT buttons

These buttons are used to switch the video and audio input signals. They can also be used to switch the input signals to the internal reference signal selected as the setup menu item No.600 (INT SG) setting.

VIDEO:

Each time the VIDEO button is pressed, the input video signal selection is switched in the order of [Y PB PR] → [CMPST] → [SDI] → [1394] → [SG].

- When SG has been selected, the signal is switched to the internal reference signal selected as the setup menu item No.600 (INT SG) setting.

AUDIO:

Each time the AUDIO button is pressed, the input audio signal selection is switched in the order of [ANALOG] → [SDI] → [1394] → [SG].

Notes:

- It is possible to inhibit the input switch operations (video and audio) of the INPUT SELECT buttons using setup menu item No.112 (V IN SEL INH) and item No.113 (A IN SEL INH).
- The Y PB PR and CMPST settings for the VIDEO button as well as the ANALOG setting for the AUDIO button cannot be selected unless the optional board (AJ-YA93P) has been installed.
- The SDI setting for the VIDEO and AUDIO buttons cannot be selected unless the optional board (AJ-YA94G) has been installed.

⑫ PF button

When this button is pressed, buttons ⑬ to ⑮ function as the PF1, PF2 and PF3 buttons, respectively. When it is pressed again before another button is pressed, these modes are canceled.

When this button is pressed together with the MENU/DIAG button ⑯, the DIAG screen is displayed.

⑬ COUNTER/PF1 button

Each time this button is pressed, the counter display on the display panel changes by one step in the following sequence: CTL → TC → UB.

⑭ RESET/PF2 button

When this button is pressed in the CTL mode, the counter display is reset to [00:00:00:00].

When it is pressed in the TC/UB mode while holding down the TC PRESET button ⑮, the generator is reset.

⑮ TC PRESET/PF3 button

This button is used to set the TC or UB values.

⑯ MENU/DIAG button

When this button is pressed, the setup menus are displayed on the TV monitor (but only when the VIDEO MON connector is used), and the setup menu numbers are displayed on the unit's display panel.

When it is pressed again, the setup menu settings are exited, and the original status is restored.

When the button is pressed while holding down the PF button ⑫, the VTR information is displayed. When it is pressed again, the original display is restored. The VTR information consists of the WARNING, HOURS METER, UMID and DIF STATUS 1, 2 information. The SEARCH button is used to switch the displays between these kinds of information.

Descriptions of the warnings are displayed on the WARNING screen. The deck's serial number, power-on time, drum rotation time, tape travel time, number of loading times, number of power on/off times, etc. are displayed on the HOURS METER screen. The UMID (Unique Material Identifier) information is displayed on the UMID INFO screen. The IEEE 1394 digital interface information is displayed on the DIF STATUS 1, 2 screen.

⑰ TCG switch

REGEN:

The internal time code generator is synchronized with the time code which the time code reader has read from the tape.

The signal that is to be used for regeneration is selected using setup menu No. 503 (TCG REGEN).

PRESET:

The time code generator can be preset (see page 35) on the operation panel or by remote control.

EXT:

The external time code which is input from the time code input connector or video signal VITC, or IEEE1394 digital input signal is used. Which of the two is to be set is selected using setup menu No. 505 (EXT TC SEL).

⑱ SUPER switch

ON : The time code and other superimposed information are output to the VIDEO MON connector.

OFF : No superimposed information is output.

Parts and their functions (continued)

Front panel

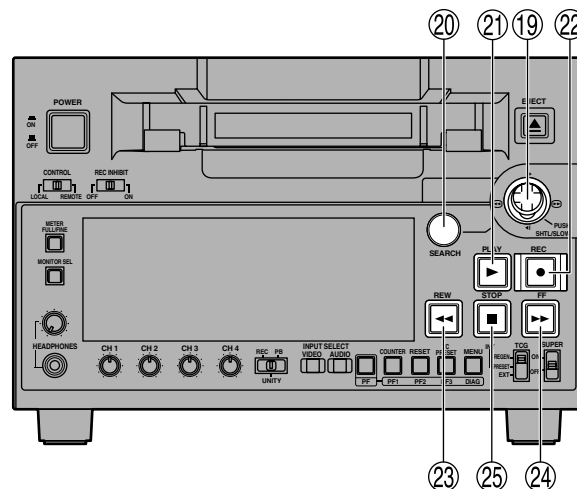

19 Joystick

This is used for shuttle, slow and other variable-speed playback. It is also used for the menu settings, etc. The stick can be moved upward, downward, to the left or to the right, and it can also be pressed to initiate operations.

20 SEARCH button

When this button is pressed, the search mode is established.

21 PLAY button

When this button is pressed, playback starts. When this button and the REC button are pressed together, recording starts.

22 REC button

When this button is pressed together with the PLAY button, recording starts.

When it is pressed during playback, a search, fast forwarding or rewinding, the E-E mode pictures and audio signals can be monitored while it is held down.

When it is pressed in the stop mode, the E-E mode pictures and audio signals can be monitored. (When it is pressed during playback, the servo will be disrupted.) When the STOP button is pressed, the original pictures and sound are restored.

23 REW button

When this button is pressed, the tape is rewound. The rewinding speed can be selected using setup menu No.102 (FF. REW MAX).

24 FF button

When this button is pressed, the tape is fast forwarded. The fast forwarding speed can be selected using setup menu No.102 (FF. REW MAX).

25 STOP button

When this button is pressed, the tape stops traveling, and when TAPE has been selected for the setup menu item No.122 (STOP EE SEL) setting, the still images can be monitored.

Even in the stop mode, the drum continues to rotate, and the tape remains in close contact with the drum.

When the stop mode continues beyond a specific time period, the unit is automatically set to the standby OFF mode or STEP FWD mode in order to protect the tape. (This is set using setup menu item No.400 to 403.) Immediately after a cassette has been loaded in the unit, the stop mode is established.

Parts and their functions (continued)

Display panel

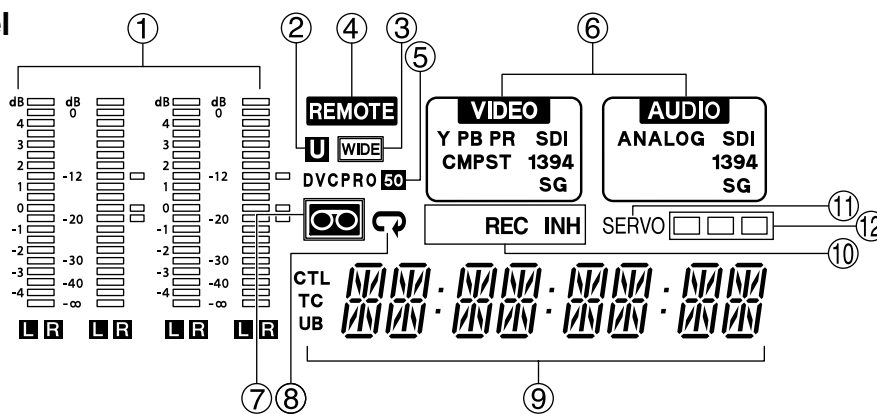

① Level meter

This displays the levels of the PCM audio signals for CH1, CH2, CH3 and CH4.

During recording and when the E-E mode is selected, it shows the levels of the input audio signals; during playback, it shows the levels of the output audio signals.

The audio level display is switched between the FULL mode and FINE mode using the METER selector button ⑥. (See page 8)

For AJ-SD93P

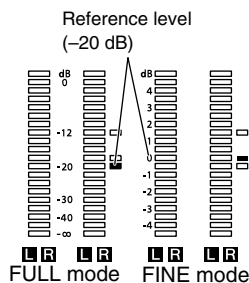

For AJ-SD93E

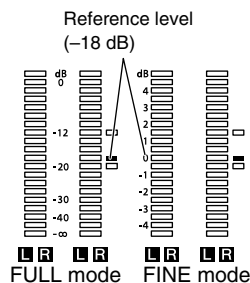

② U lamp

This lamp lights when UMID information is present on the input signal in E-E mode.

This lamp lights during tape playback when UMID information has been recorded on the tape.

③ WIDE lamp

This lamp lights when 16:9 wide-screen information is being recorded on a tape.

Recording of wide-screen information can be selected on setup menu No. 645 (WIDE SELECT).

This lights lamps during tape playback when wide-screen information has been recorded on the tape.

④ REMOTE lamp

This lamp lights when the CONTROL switch has been set to the REMOTE position.

⑤ Format displays

The recording format and the format of the tape inserted in the unit are displayed here.

⑥ INPUT SELECT display area

The characters corresponding to the selected input signals light up in this area. With the exception of analog audio signals, flashing appears in this area if the selected input signals are not available.

VIDEO

Y PB PR : Analog component video signals (option)

CMPST : Analog composite video signals (option)

SDI : Serial digital video signals (option)

1394 : IEEE1394 digital signals

SG : Internal reference signal

AUDIO

ANALOG : Analog audio signals (option)

SDI : Serial digital audio signals (option)

1394 : IEEE1394 digital signals

SG : Internal reference signal

⑦ Cassette lamp

This lamp lights when a cassette tape is inserted into the VTR.

In the standby OFF mode, this lamp is flashing.

⑧ Repeat lamp

This lights when the repeat play mode has been set.

⑨ Counter display

The tape counter, time code, etc. are displayed here.

The type of value displayed is indicated by CTL, TC or UB.

⑩ REC/REC INH lamps

REC:

This lights in the recording mode.

REC INH:

This lights in the recording inhibit mode which is established either when the REC INHIBIT switch ⑤ has been set to ON or the cassette has been set to the accidental erasure prevention status. Recording is not possible while this lamp is lighted.

Whether the lamp is to light or flash when the accidental erasure prevention tab on the cassette tape has been set to the recording inhibit position can be selected using setup menu item No.114 (REC INH LAMP).

⑪ SERVO lamp

This lights when both the drum servo and capstan servo are locked.

⑫ Channel condition lamps

These lamps light to indicate the error rate status.

(green → white → red)

Green : This lights when the error rates for the video and audio playback signals are both at acceptable levels.

White : This lights when the error rate for the video or audio playback level has increased.

The playback picture and sound remain unaffected even while this lamp is lighted.

Red : This lights when the error rate for the video or audio playback level has increased to the extent that correction or interpolation was performed.

Parts and their functions (continued)

Rear panel

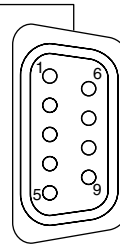
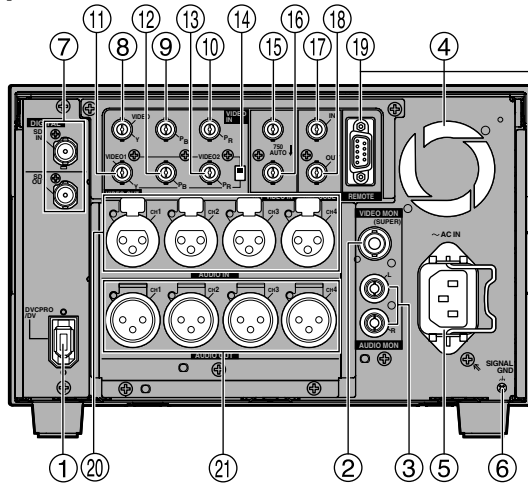

Pin No.	Signal
1	Frame Ground
2	Transmit A
3	Receive B
4	Receive Common
5	—
6	Transmit Common
7	Transmit B
8	Receive A
9	Frame Ground

① IEEE 1394 digital input/output connector
This enables signals to be input and output using the IEEE 1394 digital interface. Use a 6-pin type of connector.
Bus power is not supported.

② VIDEO MON connector
Analog composite video signals are output from this connector.
Video signals with information superimposed on them can be output. To set the superimposing to ON or OFF, use the SUPER switch ⑱ on the front panel.

③ AUDIO MON (L, R) connectors
The playback signal from the PCM audio signals (CH1, CH2, CH3, CH4) are output from these connectors.

④ Fan
This fan is used to cool down the VTR.
If, for any reason, the fan stops, "E-10" will appear on the counter display.

⑤ AC IN socket
Connect one end of the power cord supplied to this socket and the other end to the power outlet.

⑥ SIGNAL GND terminal
This is connected to the signal ground terminal on the component connected to this VTR in order to minimize noise. It is not a safety ground.

⑦ SERIAL DIGITAL COMPONENT AUDIO VIDEO IN/OUT connectors (option: AJ-YA94G)
Digital component audio/video signals complying with the SMPTE 259M-C standard are input to and output from these connectors.

Note:
The digital audio signals to be input must be synchronized with the video input signals. Otherwise, noise will be generated in the audio output signals.

⑧ ⑨ ⑩ ANALOG VIDEO IN connectors (option: AJ-YA93P)
Analog component video signals are supplied to these connectors when the INPUT SELECT button on the front panel is set to Y PB PR. Analog composite video signals are supplied using the VIDEO/Y connector ⑧ when the button is set to CMPST.

⑪ ⑫ ⑬ ANALOG VIDEO OUT connectors (option: AJ-YA93P)
Analog component video signals are output from these connectors when the ANALOG VIDEO OUT selector switch ⑭ has been set to the Y PB PR side (bottom position). Analog composite video signals are output

from the ⑪ and ⑬ connectors when the switch has been set to the VIDEO1/VIDEO2 side (top position).

⑭ ANALOG VIDEO OUT selector switch (option: AJ-YA93P)
Set this switch to the Y PB PR side (bottom position) when the ANALOG VIDEO OUT connectors are used to output component video signals; set it to the VIDEO1/VIDEO2 side (top position) when they are used to output composite video signals.

⑮ REF VIDEO IN connector (option: AJ-YA93P)
This is the input connector for the reference video signal. Input a signal with color burst.

Note:
Since the video or audio output signal may be disrupted if the reference video signal is not input, it is recommended that this connector be used by the system which supplies the reference video signals. Use a signal where SCH does not fluctuate for the reference video signal.

⑯ REF VIDEO OUT connector (option: AJ-YA93P)
This is the loop-through output connector of the REF VIDEO IN connector ⑮. When a cable is not connected to this connector, the REF VIDEO IN connector ⑮ is automatically terminated by the 75 Ω resistance. When a cable is connected, the 75 Ω termination is released.

⑰ TIME CODE IN connector (option: AJ-YA93P)
This connector is used for recording the external time code onto the tape.

⑱ TIME CODE OUT connector (option: AJ-YA93P)
The playback time code is output from this connector during playback. During recording, the time code generated by the internal time code generator is output.

⑲ Remote control connector (option: AJ-YA93P)
This enables the unit to be connected to the external remote controller for operation from an external source.

Notes:

- Set the CONTROL switch ④ to REMOTE.
- The specifications are based on the RS-422A interface, and editing-related functions do not work. In this case, use it as a player.

⑳ ANALOG AUDIO IN connectors (option: AJ-YA93P)
The analog audio signals are input from these connectors.

㉑ ANALOG AUDIO OUT connectors (option: AJ-YA93P)
The analog audio signals are output from these connectors.

Tapes

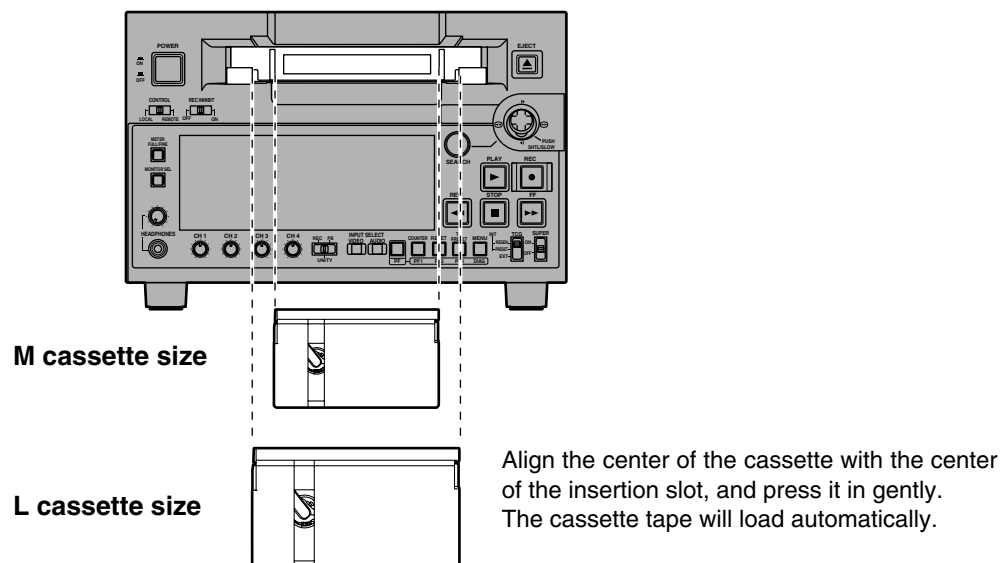

Consumer-use DV and DVCAM cassettes (Standard DV and DVCAM cassettes, mini DV and DVCAM cassettes)

- Use a cassette adapter (AJ-CS455P) when a mini DV or DVCAM cassette is to be used.

Note that inserting a mini DV or DVCAM cassette without the use of a cassette adapter will cause malfunctioning.

Also note that long-duration mini DV cassettes (80 minutes in the standard mode and 120 minutes in the LP mode) cannot be used.

- It is not possible to play back tapes which have been recorded in the LP mode.
- When editing material recorded on a consumer-use DV or DVCAM cassette, first record the material on a DVCPRO tape or other tape used by VTRs for broadcast applications.
- The maximum transport speed of a mini DV or DVCAM cassette tape is 32x.
- The images may be subject to disturbance during the slow motion playback of consumer-use DV and DVCAM cassette tapes.
- From the perspective of protecting consumer-use DV and DVCAM cassette tapes, minimize the number of times the tapes are cued up at the same locations as much as possible.
- When consumer-use DV and DVCAM cassette tapes are used, the maximum time for STILL TIMER is set to 10 seconds.

It is recommended that tapes bearing the Panasonic brand be used as the consumer-use DV tapes.

M cassettes

Tapes capable of up to 33 minutes of recording or playback

(AJ-5P23MP, AJ-5P33MP)

L cassettes

Tapes capable of up to 92 minutes of recording or playback

(AJ-5P63LP, AJ-5P92LP)

- Use AJ-5P92LP tapes which have been recorded using the DVCPRO (25M) format in a VTR that supports 184 minutes of DVCPRO (25M) format recording and playback.

IEEE 1394 digital interface

The recording format for IEEE 1394 digital input data is determined based on the table below.

Setup menu No. 012 (SYS FORMAT) settings	Input data	Recording format data	
50M	DVCPRO50	DVCPRO50	
	DVCPRO	Recording not possible	
	DV	Recording not possible	
25M	DVCPRO50	Recording not possible	
	DVCPRO	DVCPRO	
	DV	For AJ-SD93P * 1: DVCPRO	
		For AJ-SD93E: Recording not possible	

* 1 If the audio of the input data is 32 kHz/4CH, CH1/CH2 and CH3/CH4 can be selected in setup menu No. 889 (DIF AUD IN).

For AJ-SD93P:

The format for IEEE 1394 digital output data is determined based on the setup menu No. 881 (DIF TYPE) setting and playback tape (mode).

Mode	Setup menu No. 012 (SYS FORMAT) setting	Setup menu No. 881 (DIF TYPE) setting	Output data format
During DVCPRO50 tape playback	—	—	DVCPRO50
During DVCPRO tape playback	—	AUTO	DVCPRO
	—	DVCPRO	DVCPRO
	—	DV	DV
During DV/DVCAM tape playback	—	AUTO	DV
	—	DVCPRO	DVCPRO
	—	DV	DV
During EJECT or E-E	50 M	—	DVCPRO50
	25 M	AUTO	DVCPRO
		DVCPRO	DVCPRO
		DV	DV

For AJ-SD93E:

The format for IEEE 1394 digital output data is determined based on the playback tape (mode).

Mode	Setup menu No. 012 (SYS FORMAT) setting	Output data format
During DVCPRO50 tape playback	—	DVCPRO50
During DVCPRO tape playback	—	DVCPRO
During DV/DVCAM tape playback	—	DV
During EJECT or E-E	50 M	DVCPRO50
	25 M	DVCPRO

Precautions for use

- Connect the interface with another device on a 1:1 basis.
- If the E-92 warning (1394 INITIAL ERROR) is displayed, either re-connect the connecting cable or turn the VTR's power off and back on.
- The AV signals may be disrupted when the power of the connected devices is turned on or off and when the interface cable is connected or disconnected.
- When the input signals are switched or the mode is transferred, it may take a few seconds for the system to stabilize. Proceed with the recording operation only after the system has stabilized.
- The following situation applies when recording is to be performed by selecting the IEEE 1394 digital interface input, and it applies with the signals which are output by the IEEE 1394 digital interface.
 - The audio level control knobs on the front panel do not work.
 - The settings in the 800 series of setup menu items concerning the vertical blanking period are ignored.
 - When playback signals other than regular 1x speed playback signals have been input, no guarantees are made for the pictures and sound which will be recorded or for the EE-type pictures and sound.
- The following situation applies when the video input selection has been set as the IEEE 1394 digital interface.
 - The SDI signals, the analog video output signals and time code output signals become irregular in the E-E mode. Do not use these signals for recording purposes. (The teletext signals and other signals superimposed onto the video output signals also become irregular.)
- During SLOW/STILL playback, unprocessed video and audio signals are output as the IEEE 1394 digital interface output. When these video and audio signals are monitored using another device, they may differ from the video and audio signals played back by this unit.

Be absolutely sure not to defeat the following safeguards when connecting the IEEE 1394 cable.

(1) Ensure that the unit and all devices to be connected are grounded (or connected to a common ground).

If the equipment cannot be grounded, first turn off the power of all the connected devices, and then disconnect and re-connect the IEEE 1394 cable.

(2) When connecting the unit to a device equipped with a 4-pin connector, connect the unit's connector (6-pin type) first.

(3) When making a connection to a PC equipped with a 6-pin connector, connect the 1394 cable so that it mates properly with the 1394 connector. Bear in mind that if the plug is inserted the wrong way round, the unit may be damaged as a result.

Joystick

(1) Press the SEARCH button to activate the joystick.

When STICK has been selected as the setup menu item No.100 (SEARCH ENA) setting, the joystick will be activated without pressing the SEARCH button.

(2) Press the joystick to switch between the SHTL mode and SLOW mode.

(3) When the joystick is inclined toward the right, the tape can be played back in the forward direction at a variable speed based on the angle that the stick is inclined. When the stick is inclined toward the left, the tape is played back in the reverse direction.

• SHTL mode:

The maximum speed which is established when the joystick has been inclined at the maximum angle corresponds to the speed which has been set by setup menu item No.101 (SHTL MAX).

• SLOW mode:

The speed ranges from -1.0x to +1.0x.

(4) When the joystick is inclined upward, the tape travels in 1-frame increments in the forward direction; when it is inclined downward, it travels in 1-frame increments in the reverse direction.

Slow playback is performed if the stick is held at the top or bottom position.

- If the SEARCH button is pressed while the joystick is pressed to one side, the current speed is maintained even if the joystick is released. Pressing the STOP, PLAY, or other operation buttons cancels the fixed speed operation.

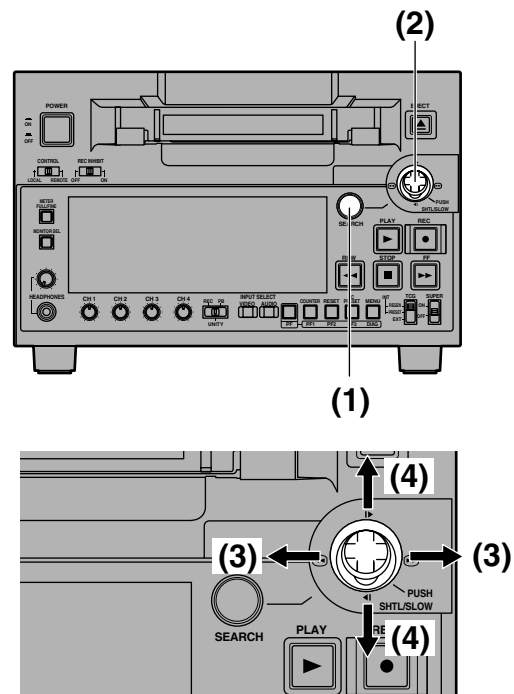

PF (Programmable Function)

Three setup menu items can be registered in the PF buttons, and these buttons can then be used to change the setup menu settings by a simple operating procedure.

Registering the items in the PF buttons

- (1) Press the MENU button, and open the setup menu.
- (2) Incline the joystick upward or downward to select the PF number item (A04-A06) to be registered.

```

SETUP-MENU  MENU
<USER1> NO .A04-
A02 P ON LOAD OFF
*A04 PF1 ASSIGN 012
A05 PF2 ASSIGN 513
A06 PF3 ASSIGN ---
END
    
```

- (3) When the joystick is pressed, a list of items which can be set is displayed.

```

SETUP-MENU MENU
<USER1> NO .A04-
A04 PF1 ASSIGN ---
*--- NO ASSIGN
001 LOCAL ENA
002 TAPE TIMER
003 REMAIN SEL
008 DISPLAY SEL
009 CHARA H-POS
010 CHARA V-POS
    
```

- (4) Incline the joystick upward or downward to select the item.
- (5) When the joystick is pressed, the regular menu display screen is restored. When the MENU button is pressed, a confirmation screen appears. Press the PLAY button to set.

Performing operations using the PF buttons

- (1) When the PF button is pressed, the registered items are displayed on the monitor screen which is output from the VIDEO MON connector.

```

PF1: SYS FORMAT 50M
PF2: INT SG CB75
PF3: -----
    
```

- (2) Press the PF1, PF2 or PF3 button that corresponds to the item whose setting is to be changed. Each time the button is pressed, the setting is updated in sequence.
- (3) When the PF button is pressed again, the regular display is restored. If no operations are made, the display is also restored automatically after five seconds elapse.

Repeat playback

■ Setting the BEGIN and END points

- (1) Press the MENU button.
- (2) Select menu item No.161 (CTL(TC)BGN) or No.162 (END), and incline the joystick to the left or right.

By operating the joystick, the user can choose whether or not to set the BEGIN and END points.

“--:--:--:--” appears on the display when the points are not set. If repeat playback is initiated in this state, the tape start will serve as the BEGIN point, and the tape end will serve as the END point.

- (3) Press the joystick while the setting is displayed. The changed digits flash on the display.
- (4) Select TC or CTL using the COUNTER button.
- (5) Incline the joystick to the left or right, and select the digits to change (flashing).

The frame digits cannot be selected. “00” is always displayed for these digits.

When the joystick is now inclined upward or downward, the value of the digits changes.

The counter display is reset to 00:00:00:00 when the RESET button is pressed.

- (6) After the settings have been completed, press the joystick.
- (7) Press the MENU button.

A confirmation screen now appears. The settings are stored in the memory when the PLAY button is pressed.

■ Setting the repeat playback mode

- (1) Press the MENU button.
- (2) Select menu item No.160 (MEMORY MODE), and select the repeat playback mode.

Item setting	Description of operation
OFF	Normal operation
M-STOP	When the tape is fast forwarded or rewind, it stops near the BEGIN point.
REPT1	When the tape is played as far as the END point, it is rewind to the BEGIN point where it stops.
CONT	When the tape is played as far as the END point, it is rewind to the BEGIN point and played, and this sequence of operations is repeated.

- (3) Press the MENU button.

A confirmation screen now appears. The settings are stored in the memory if the PLAY button is now pressed.

Notes:

- The picture quality deteriorates when repeat playback is initiated for the same tape over and over again. As a general rule of thumb, replace the tape with a new one after playing back the tape for about 100 times.
- The output images to be displayed while the tape is being rewind to the BEGIN point in the repeat playback mode can be set using menu item No.163 (REPT MODE).
If FREEZE is selected as the REPT MODE setting and the tape end has been set as the END point, the playback image will not be frozen properly. Set the END point at a place on the tape where images have been recorded.
- If the counter display mode (TC or CTL), which was established when menu item No.161 (CTL(TC)BGN) and No.162 (END) were set, is different from the counter display mode (TC or CTL) in which repeat playback is to be initiated, the repeat lamp flashes, and the repeat playback operation cannot be performed.

Setup (initial settings)

The unit's main settings are performed while making selections using a menu-driven system.

When a TV monitor is connected to the VIDEO MON connector on the unit's rear panel, the setup menu will appear on the TV monitor.

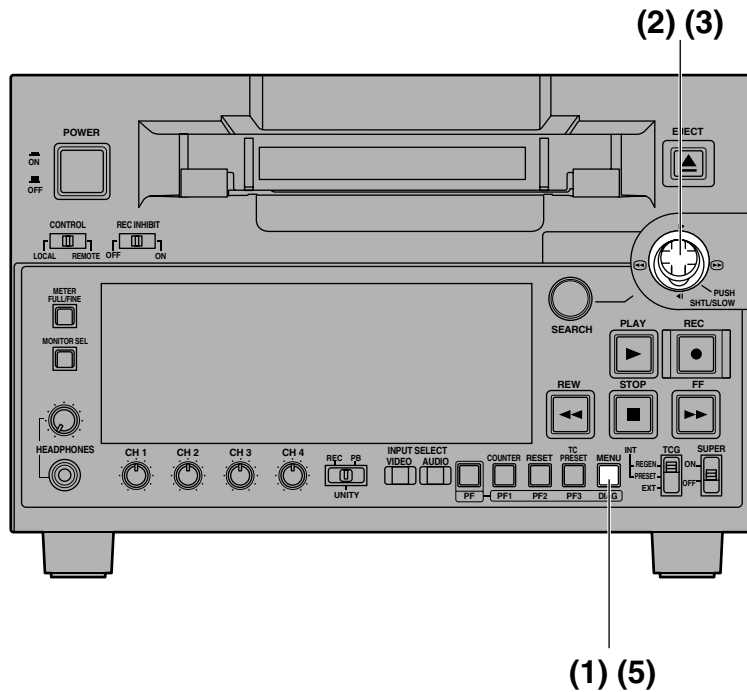

■ Changing the settings

(1) Press the MENU button.

The setup menu screen appears on the TV monitor, and the setup menu item number appears on the counter display.

When the FF button is pressed for about 1.5 seconds, the name of the setup menu item is displayed on the counter display. When the same button is pressed again for about 1.5 seconds, the original item No. display is restored.

(If a setup was performed previously, the screen on which the last change was made is displayed.)

(2) Incline the joystick upward or downward to select the item to be set.

The cursor (*) on the menu screen moves, and the item number on the display flashes.

- When the FF or REW button is pressed while holding down the PLAY button, what is on the display is replaced with the next or previous major item.

(3) Incline the joystick to the left or right at the position where the change is to be made.

The setting is now changed.

To return what has been established as the setting to the factory setting, press the RESET button while holding down the SEARCH button.

(4) If there is another item to be changed, repeat steps (2) to (3).

(5) Press the MENU button.

- If none of the settings have been changed, the menu screen display is cleared.
- If a setting has been changed, a confirmation screen appears.
- To activate the change in the setting, press the PLAY button.
- To cancel the change in the setting, press the STOP button.
- To return what has been established as the setting to the factory setting, press the RESET button while the menu is displayed. A confirmation screen now appears, and if the PLAY button is pressed in this status, the factory setting is restored.

Notes:

- If the RESET button is pressed to restore the factory settings, only the user files currently in use are restored. The other user files remain unaffected.
- The changes made to the SYSTEM menu contents are recorded also by pressing the MENU button to close the menu screen.

Setup menus

This VTR can hold five user files, each of which has its own specific menu settings, and one of these files can be selected for use.

■ Changing the file

(1) Press the MENU button.

(2) When the FF button is pressed while holding down the PF button, the next user file is selected; conversely, when the REW button is pressed while holding down the PF button, the previous user file is selected.

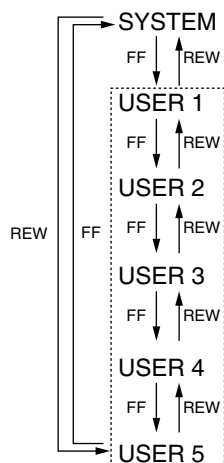

User files

Each user file contains the following items.

- BASIC
- OPERATION
- INTERFACE
- TAPE PROTECT
- TIME CODE
- VIDEO
- AUDIO
- V BLANK
- DIF
- MENU

(3) Decide on the user file to be used in the step (2) operation, and press the MENU button.

A confirmation screen now appears.

(4) When the PLAY button is pressed, what has been set is stored in the memory.

■ Setting and releasing the lock mode

The lock mode can be set to protect the system file and user file (USER2 to USER5) settings. Once the lock mode is set, no further changes can be made to the settings.

Setting and releasing the lock mode can be set for the system file by using setup menu No. 30 (MENU LOCK) and for the user files by using setup menu No. A03 (MENU LOCK).

(1) Press the MENU button.

(2) Press the REW button or FF button while holding down the PF button to select the file for which the lock mode is to be set or released.

(3) Operate the joystick to move the cursor (*) on the menu screen to item No.30 (MENU LOCK) for the system file or to item No.A03 (MENU LOCK) for a user file.

(4) Press the SEARCH button, and use the joystick to select whether the lock mode is to be set or released.

To set the lock mode:

Select 0001 (ON) as the setting.

To release the lock mode:

Select 0000 (OFF) as the setting.

When the lock mode has been set, LOCKED flashes on the menu screen. The counter display stops flashing and remains lighted.

(5) Press the MENU button.

A confirmation screen now appears.

(6) When the PLAY button is pressed, what has been set is stored in the memory.

Notes:

- The lock mode cannot be set for the USER1 file.
- Once set to the lock mode, a file cannot be reset to the factory settings even by pressing the RESET button.

Setup menus (continued)

■ Loading user files

The contents of the USER2, USER3, USER4 or USER5 file can be copied (loaded) into the USER1 file. Also, the contents of the USER1 file can be copied (saved) into the USER2, USER3, USER4 or USER5 file.

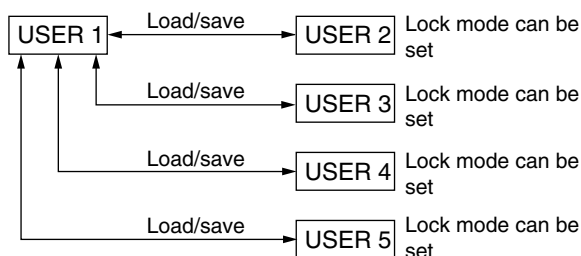

- (1) Press the MENU button.
- (2) Press the REW button or FF button while holding down the PF button to select the USER1 file.
- (3) Operate the joystick, and move the cursor (*) on the menu screen to item No.A00 (LOAD).

```

SETUP-MENU  MENU
<USER1>    NO .A00-0000
804 BLANK LINE   BLANK
*A00 LOAD        USER2
A01 SAVE        USER2
A02 P. ON LOAD  OFF
END
    
```

- (4) Press the joystick, and incline it to the left or right to select the user file whose contents are to be loaded into USER1.
- (5) Press the joystick.

The following message appears on the menu screen and counter display.

Menu screen

```

SETUP-MENU  LOAD
USER2 → USER1 OK?
YES<PLAY>/NO<STOP>
    
```

Counter display



The number of the user file selected in step (4) is displayed at ■.

- (6) Press the PLAY button

The settings of the user file selected in step (4) are loaded, and the USER1 menu display appears. If the STOP button is pressed instead, the settings are not changed, and the USER1 menu display appears.

- (7) Press the MENU button.

A confirmation screen now appears.

When the PLAY button is pressed, the USER1 settings are stored in the memory. If the settings are not to be stored in the memory, press the STOP button instead.

■ Saving user files

- (1) Press the MENU button.
- (2) Press the REW button or FF button while holding down the PF button to select the USER1 file.
- (3) Operate the joystick, and move the cursor (*) on the menu screen to item No.A01 (SAVE).

```

SETUP-MENU  MENU
<USER1>    NO .A00-0000
804 BLANK LINE   BLANK
A00 LOAD        USER2
*A01 SAVE        USER2
A02 P. ON LOAD  OFF
END
    
```

- (4) Press the joystick, and incline it to the left or right to select the user file in which the contents of USER1 are to be saved.

Those user files which have been set to the lock mode do not appear on the display. If all the user files have been set to the lock mode, the "LOCKED" display appears, and the contents of USER1 cannot be saved into any of the user files.

- (5) Press the joystick.

The following message appears on the menu screen and counter display.

Menu screen

```

SETUP-MENU  SAVE
USER1 → USER2 OK?
YES<PLAY>/NO<STOP>
    
```

Counter display

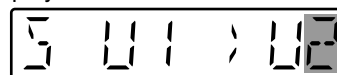

The number of the user file selected in step (4) is displayed at ■.

- (6) Press the PLAY button

The settings of USER1 are saved in the user file selected in step (4) and stored in the memory. If the STOP button is pressed instead, the settings are not changed, and the USER1 menu display appears.

- (7) Press the MENU button.

The regular display is restored.

■ Automatically recalling a user file when turning on the power

If the user file to be loaded is selected in advance using setup menu No. A02 (P.ON LOAD), the file will be automatically loaded into USER1 when the power is turned on.

Setup menus (continued)

SYSTEM menu

No./Item	Description
11 SYS SC YA93P	System phase adjustment: Variable range $\pm 180^\circ$ -: Advanced, +: Delayed 0000 -128 Note: : : If setting operation is <u>0128</u> <u>0</u> performed, the setting : : value does not return to 0255 127 factory (default) setting.
13 SYS H YA93P	System phase adjustment: 74 ns steps -: Advanced, +: Delayed 0000 -128 Note: : : If setting operation is <u>0108</u> <u>0</u> performed, the setting : : value does not return to 0216 127 factory (default) setting.
14 SCH COARSE YA93P	SCH phase adjustment: 90° units (The SC phase changes but the H phase does not change.) -: Advanced, +: Delayed 0000 0 0001 90 0002 180 0003 270
15 SCH FINE YA93P	SCH phase adjustment: Total variable range: $\pm 45^\circ$ or more (The SC phase changes but the H phase does not change.) -: Advanced, +: Delayed 0000 -32 : : <u>0032 0</u> : : 0064 32
16 AV PHASE YA93P YA94G	This adjusts the audio output phase with respect to the video output: 20.8 μ s steps -: The audio output phase is advanced with respect to the video output. +: The audio output phase is delayed with respect to the video output. 0000 -128 : : <u>0128 0</u> : : 0255 127

No./Item	Description
18 SYS H OFFSET YA93P	System phase adjustment. 0000 -3 : -13.4 μ sec 0001 -2 : -8.96 μ sec 0002 -1 : -4.52 μ sec <u>0003 0</u> : 0 sec 0004 1 : +4.52 μ sec 0005 2 : +8.96 μ sec 0006 3 : +13.4 μ sec Note: If setting operation is performed, the setting value does not return to factory (default) setting.
22 VIDEO LEVEL YA93P YA94G	This sets the video level. Max. variable range: ± 3 dB 0000 -128 : : <u>0128 0</u> : : 0255 127
23 (For AJ-SD93P) SET UP LEVEL (For AJ-SD93E) BLACK LEVEL YA93P YA94G	This sets the setup (black) level. Max. variable range: 14 IRE (100 mV) 0000 -128 : : <u>0128 0</u> : : 0255 127
24 (For AJ-SD93P) HUE (For AJ-SD93E) CHROMA PHASE YA93P YA94G	This sets the hue (chroma phase). Max. variable range: $\pm 30^\circ$ 0000 -128 : : <u>0128 0</u> : : 0255 127
25 CHROMA LEVEL YA93P YA94G	This sets the chroma level. Max. variable range: ± 3 dB 0000 -128 : : <u>0128 0</u> : : 0255 127
30 MENU LOCK YA93P YA94G	This selects whether the system file lock mode is to be engaged or released. 0000 OFF : The lock is released (file data can be changed). 0001 ON : The lock is engaged (file data cannot be changed).

The underlined items indicates the initial setting.

YA93P This appears only when the optional board AJ-YA93P has been installed.

YA94G This appears only when the optional board AJ-YA94G has been installed.

Setup menus (continued)

■ USER menu <BASIC>

No./Item	Description
001 LOCAL ENA	<p>This selects the buttons which can be operated on the front panel when the CONTROL switch has been set to REMOTE.</p> <p>0000 DIS : No buttons can be operated.</p> <p>0001 <u>ST&EJ</u> : Only the STOP and EJECT buttons can be operated.</p> <p>0002 ENA : All buttons can be operated.</p>
002 TAPE TIMER	<p>This selects the 12 or 24 hour display for the CTL counter.</p> <p>0000 <u>±12h</u> : 12 hour display 0001 24h : 24 hour display</p>
003 REMAIN SEL	<p>This selects whether the remaining tape time and total tape length are to be displayed in the superimposed display of the VIDEO MON connector signals.</p> <p>0000 OFF: No display. 0001 <u>2L</u> : The remaining tape time is displayed on the second line. 0002 1L : The remaining tape time is displayed on the first line. 0003 <u>R/TTL</u> : The remaining tape time is displayed on the first line, and the total tape length is displayed in the second line.</p> <p>Notes:</p> <ul style="list-style-type: none"> • When "2L" is selected, the remaining tape time is not displayed if "TIME" or "VITC" has been selected as the setup menu item No.008 (DISPLAY SEL) setting. • When "R/TTL" is selected, the total tape length is not displayed if "TIME" or "VITC" has been selected as the setup menu item No.008 (DISPLAY SEL) setting.

No./Item	Description
008 DISPLAY SEL	<p>This selects what information is to be provided by the time code and other super displays output to the VIDEO MON connector.</p> <p>0000 TIME : Data only. (The data indicates the value for whichever of CTL, TC or UB currently selected by the COUNTER button.)</p> <p>0001 <u>T&STA</u> : Data and operation status.</p> <p>0002 <u>T&S&M</u> : Data, operation status and mode.</p> <p>0003 T&RT : Data and REC TIME 0004 <u>T&YMD</u> : Data and REC DATE (year/month/day)</p> <p>0005 T&MDY : Data and REC DATE (month/day/year)</p> <p>0006 T&DMY : Data and REC DATE (day/month/year)</p> <p>0007 T&UB : Data and user bit. However, when UB has been selected with the COUNTER button, the time code is displayed after the user bit.</p> <p>0008 T&CTL : Data and CTL data. However, when CTL has been selected with the COUNTER button, the time code is displayed after the CTL data.</p> <p>0009 T&T : The data and time code recorded in the VAUX area are displayed.</p> <p>0010 VITC: The time code and user bit recorded in the VAUX area are displayed.</p> <p>Notes:</p> <ul style="list-style-type: none"> • Mode display: DVCPRO 50 (50 Mbps) = DVCPRO_50, DVCPRO (25 Mbps) = DVCPRO, DV = DV, DVCAM = DVCAM • An error message appears if a warning or error has occurred when "T&S&M" has been selected as this setting. • REC TIME and REC DATE are displayed during DV/DVCAM, playback only. With the DVCPRO50 (50 Mbps) or DVCPRO (25 Mbps) format, the operating mode is displayed.

The underlined items indicates the initial setting.

Setup menus (continued)

■ USER menu <BASIC>

No./Item	Description
009 CHARA H-POS	<p>This sets the position of the characters on the horizontal plane for the time code and other super displays output to the VIDEO MON connector.</p> <p>0000 0 : : <u>0004</u> 4 : : 0016 16</p> <p>Note: Press the joystick, then you can set the position of the characters by inclining it up or down or to the left or right.</p>
010 CHARA V-POS	<p>This sets the position of the characters on the vertical plane for the time code and other super displays output to the VIDEO MON connector.</p> <p>(For AJ-SD93P) (For AJ-SD93E) 0000 0 0000 0 : : : : <u>0018</u> 18 <u>0023</u> 23 : : : : 0022 22 0028 28</p> <p>Notes:</p> <ul style="list-style-type: none"> • Press the joystick, then you can set the position of the characters by inclining it up or down or to the left or right. • When the DISPLAY SEL status causes characters to extend beyond the edges of the screen, the setting value is changed but the characters are automatically displayed at a position on the screen where they will not extend.
011 CHARA TYPE	<p>This selects the display type for the super display output to the VIDEO MON connector as well as for displays such as the setting menu, etc.</p> <p>0000 <u>WHITE</u> : White characters against a black background. 0001 <u>W/OUT</u> : White characters with a black border.</p>

No./Item	Description
012 SYS FORMAT	<p>This sets the VTR's recording and playback format.</p> <p>0000 <u>50M</u> : DVCPRO50 (50 Mbps) is selected. 0001 <u>25M</u> : DVCPRO (25 Mbps) is selected.</p> <p>Note: The format complies with the setting of this menu item when the tape is ejected.</p>
013 PB FORMAT	<p>This sets the format in which the tape is to be played back.</p> <p>0000 <u>MANUAL</u> : The format complies with the setting of setup menu No. 012 (SYS FORMAT) when a DVCPRO cassette is inserted. The format complies to the format recorded on the tape when a DV or DVCAM cassette is inserted. 0001 <u>AUTO</u> : The format complies with the format recorded on the tape.</p> <p>Note: When AUTO has been selected, the picture and sound may be disturbed until the format is detected after a tape is loaded.</p>
017 CHARA SIZE	<p>This selects the size of the characters for the superimposed display output from the VIDEO MON connector.</p> <p>0000 <u>NORMAL</u> : Standard size 0001 <u>LARGE</u> : 4 times larger than the standard size</p> <p>Note: When LARGE has been selected, only time data is displayed, regardless of the setup menu No.008 (DISPLAY SEL) setting.</p>

The underlined items indicates the initial setting.

Setup menus (continued)

■ USER menu <OPERATION>

No./Item	Description
100 SEARCH ENA	<p>This sets the method used to transfer to the search mode (stick operation).</p> <p><u>0000</u> STICK : Operation transfers to the search mode when the SEARCH button is pressed or the stick is operated.</p> <p>0001 KEY : Operation is not transferred to the search mode unless the SEARCH button is pressed.</p>
101 SHTL MAX	<p>This sets the maximum speed for shuttle</p> <p>0000 x8.4 : 8.4x normal speed 0001 x16 : 16x normal speed 0002 x32 : 32x normal speed</p>
102 FF. REW MAX	<p>This sets the maximum speed for FF and REW operations.</p> <p>0000 x16 : 16(32)x normal speed 0001 x32 : 32(60)x normal speed 0002 x50 : 50(100)x normal speed</p> <p>Notes:</p> <ul style="list-style-type: none"> The speeds given in the parentheses apply in the DVCPRO (25 Mbps), DV and DVCAM mode. With mini DV or mini DVCAM cassette, the maximum speed is set to 32x regardless of this item's settings.
104 REF ALARM	<p>This selects whether to warn the operator when the REF. VIDEO signal has not been connected.</p> <p>0000 OFF : Warning is not given.</p> <p>0001 ON : Warning is given by the flashing STOP lamp.</p> <p>Note: Video and audio output may be disturbed when the reference video signal is not input, so it is recommended that a system which inputs the reference video signal be used.</p> <p>YA93P</p>
107 PLAY DELAY	<p>This set the play delay time in frame increments.</p> <p><u>0000</u> 0 : : 0015 15</p>
108 CAP.LOCK	<p>This selects the CAPSTAN LOCK mode.</p> <p>(For AJ-SD93P) (For AJ-SD93E)</p> <p>0000 2F : 2F mode 0000 2F : 2F mode 0001 4F : 4F mode 0001 4F : 4F mode 0002 8F : 8F mode</p> <p>Note: Color framing for the VIDEO MON connector output is not guaranteed.</p> <p>YA93P</p>

No./Item	Description
109 AUTO REW	<p>This selects whether to rewind the tape automatically to the tape start when the tape end is detected.</p> <p>0000 OFF : The tape stops at the tape end.</p> <p>0001 ON : The tape is rewound to the tape start.</p> <p>Note: The tape stops near the BEGIN point when setup menu No. 160 (MEMORY MODE) is set to M-STOP.</p>
111 FRZ MODE SEL	<p>This selects the output picture in the STANDBY OFF (HALF LOADING) and EJECT modes.</p> <p>0000 DIS : The video output is muted.</p> <p>0001 STB OFF : When the STANDBY OFF (HALF LOADING) mode is established, the picture being played back at the time is frozen and output.</p> <p>0002 SOF&EJ : When the STANDBY OFF (HALF LOADING) or EJECT mode is established, the picture being played back at the time is frozen and output.</p> <p>Notes:</p> <ul style="list-style-type: none"> The freeze status complies with the setup menu item No.605 (FREEZE SEL) setting. The playback screen freezes only when setup menu No. 122 (STOP EE SEL) is set to STOP. In the EJECT mode, the freeze image is output only when BLACK or GRAY is selected as the setup menu item No.120 (EJECT EE SEL) setting.
112 V IN SEL INH	<p>This selects whether video input switching using the INPUT SELECT button is to be enabled or disabled.</p> <p>0000 OFF : Video input switching using the INPUT SELECT button is enabled.</p> <p>0001 ON : Video input switching using the INPUT SELECT button is disabled.</p> <p>0002 REC : Video input switching using the INPUT SELECT button after the unit has been transferred to a recording (but not editing) mode is disabled.</p>
113 A IN SEL INH	<p>This selects whether audio input switching using the INPUT SELECT button is to be enabled or disabled.</p> <p>0000 OFF : Audio input switching using the INPUT SELECT button is enabled.</p> <p>0001 ON : Audio input switching using the INPUT SELECT button is disabled.</p> <p>0002 REC : Audio input switching using the INPUT SELECT button after the unit has been transferred to a recording (but not editing) mode is disabled.</p>

The underlined items indicates the initial setting.

YA93P This appears only when the optional board AJ-YA93P has been installed.

Setup menus (continued)

■ USER menu <OPERATION>

No./Item	Description
114 REC INH LAMP	<p>This selects whether to cause the REC INH lamp to flash or light up when the cassette has been set to the accidental erasure prevention status.</p> <p><u>0000 LIGHT</u> : The lamp lights up. 0001 FLASH : The lamp flashes.</p> <p>Note: When the REC INHIBIT switch is set to ON, the REC INH lamp always lights regardless of the general setting status.</p>
115 EJECT SW INH	<p>This selects whether to enable or disable the operation of the EJECT button on the front panel.</p> <p><u>0000 REC</u> : Operation is disabled while the unit is in the recording mode. 0001 OFF : Operation is enabled in all modes.</p>
120 EJECT EE SEL	<p>This selects the modes for the picture and sound output when the tape is ejected.</p> <p><u>0000 EE</u> : EE mode 0001 BLACK : The picture turns black, and the sound is muted. 0002 GRAY : The picture turns gray, and the sound is muted.</p> <p>Note: The IEEE 1394 digital output video will be black even if GRAY is selected.</p>
121 F/R EE SEL	<p>This selects whether the EE mode or playback mode is to be established during fast forwarding or rewinding.</p> <p><u>0000 EE</u> : EE mode 0001 TAPE : Playback mode</p>
122 STOP EE SEL	<p>This select whether the EE mode or playback mode is to be established when operation is stopped.</p> <p><u>0000 EE</u> : EE mode 0001 TAPE : Playback mode</p> <p>Note: The selection is complied with even in the standby OFF mode. However, the picture will turn gray (black for IEEE 1394 digital output) when TAPE is selected.</p>

The underlined items indicates the initial setting.

YA93P This appears only when the optional board AJ-YA93P has been installed.

No./Item	Description
160 MEMORY MODE	<p>This sets the repeat play mode.</p> <p><u>0000 OFF</u> : No repeat play (normal operation) 0001 M-STOP : The tape stops near the BEGIN point when a FF or REW operation has been performed. 0002 REPT1 : During playback, the tape is rewound to the BEGIN point and stopped when the END point is reached. 0003 CONT : During playback, the tape is rewound to the BEGIN point and then played, and these steps are repeated when the END point is reached.</p>
161 CTL BGN or TC BGN	<p>This sets the BEGIN point in the repeat play mode.</p> <p>Whether TC or CTL is displayed on the counter when the COUNTER button is pressed is set here. When there is no setting, --:--:-- appears, and the tape start serves as the BEGIN point.</p>
162 END	<p>This sets the END point in the repeat play mode.</p> <p>Whether TC or CTL is displayed on the counter when the COUNTER button is pressed is set here. When there is no setting, --:--:-- appears, and the tape end serves as the END point.</p>
163 REPT MODE	<p>This sets the output image when the tape returns to the BEGIN point in the repeat play mode.</p> <p><u>0000 FREEZE</u> : The tape returns to the BEGIN point while the playback image at the END point remains frozen. 0001 BLACK : The tape returns to the BEGIN point while a BLACK picture remains on the screen. 0002 EE_SEL : The tape returns to the BEGIN point with an image which is in compliance with the setup menu item No.121 (F/R EE SEL) setting.</p> <p>Note: If, when FREEZE has been selected, the END point has been set at the tape end, the playback image will not be frozen properly. Set the END point in a range where pictures have been recorded.</p>

■ USER menu <INTERFACE>

No./Item	Description
202 ID SEL	<p>This sets the ID information to be returned to the controller.</p> <p><u>0000 OTHER</u> : 0001 DVCPRO : 0002 ORIG :</p> <p>Notes:</p> <ul style="list-style-type: none"> • ID information of any VTR except for the DVCPRO's is set in OTHER. • The ORIG setting should only be used when a Panasonic controller (AG-A850 etc. sold separately) is connected.

YA93P

Setup menus (continued)

■ USER menu <TAPE PROTECT>

No./Item	Description
400 STILL TIMER	<p>This selects the time to be taken until the unit goes into the tape protection mode when it is left standing in the stop or search still (JOG/SLOW/SHTL) mode. (Unit: s = second, min = minute)</p> <p>0000 0.5s 0001 5s 0002 10s 0003 20s 0004 30s 0005 40s 0006 50s 0007 1min 0008 2min</p> <p>Notes:</p> <ul style="list-style-type: none"> • STEP FWD and HALF LOADING are provided in the tape protection mode. Either of these can be set for STOP and SEARCH STILL. • The cumulative standby time at the same tape position increases when transmitting programs or otherwise using identical materials repeatedly. In order to protect the tape, it is recommended that the shortest possible setting for the standby time in the same tape location is used. • When a DV/DVCAM tape is used, any setting above 10 seconds will be treated as 10 seconds.
401 SRC PROTECT	<p>When the time selected as the setup menu item No. 400 (STILL TIMER) setting elapses while the unit is in the search STILL (JOG/SLOW/SHTL) mode, the unit automatically enters one of the tape protection modes. This menu item is for selecting which tape protection mode the unit is to enter.</p> <p>0000 STEP : STEP FWD 0001 HALF : HALF LOADING</p> <p>Note: When STEP FWD is selected, the unit automatically goes into the STANDBY OFF (HALF LOADING) mode when the total time for which the unit is left standing in the still status reaches 30 minutes (or 1 minute for a DV/DVCAM tape).</p>
402 DRUM STDBY	<p>This selects the drum operation in the STANDBY OFF (HALF LOADING) mode.</p> <p>0000 OFF : The drum stops rotating. 0001 ON : The drum continues rotating.</p>

No./Item	Description
403 STOP PROTECT	<p>When the time selected as the setup menu item No. 400 (STILL TIMER) setting elapses while the unit is in the STOP mode, the unit automatically enters one of the tape protection modes. This menu item is for selecting which tape protection mode the unit is to enter.</p> <p>0000 STEP : STEP FWD 0001 HALF : HALF LOADING</p> <p>Note: When STEP FWD is selected, the unit is automatically transferred to the STANDBY OFF (HALF LOADING) mode when the total time during which it has been left standing in the STOP mode reaches 30 minutes (or 1 minute for a DV/DVCAM tape).</p>

The underlined items indicates the initial setting.

Setup menus (continued)

■ USER menu <TIME CODE>

No./Item	Description												
500 VITC BLANK	<p>For selecting whether to output the VITC signal at the positions selected by setup menu items No. 501 (VITC POS-1) and No. 502 (VITC POS-2).</p> <p>0000 BLANK : VITC signals are not output.</p> <p>0001 THRU : VITC signals are output.</p>												
501 VITC POS-1	<p>This sets the position where the VITC signal is to be inserted.</p> <table style="width: 100%; border: none;"> <tr> <td style="text-align: center;">(For AJ-SD93P)</td> <td style="text-align: center;">(For AJ-SD93E)</td> </tr> <tr> <td style="text-align: center;">0000 10L</td> <td style="text-align: center;">0000 7L</td> </tr> <tr> <td style="text-align: center;">: :</td> <td style="text-align: center;">: :</td> </tr> <tr> <td style="text-align: center;"><u>0006 16L</u></td> <td style="text-align: center;"><u>0004 11L</u></td> </tr> <tr> <td style="text-align: center;">: :</td> <td style="text-align: center;">: :</td> </tr> <tr> <td style="text-align: center;">0010 20L</td> <td style="text-align: center;">0015 22L</td> </tr> </table> <p>Notes:</p> <ul style="list-style-type: none"> • The same line as the one used for the setup menu items No. 502 (VITC POS-2) and No. 662 (UMID POS) setting cannot be set. • The default settings are not restored even if the RESET button is pressed while holding down the SEARCH button. 	(For AJ-SD93P)	(For AJ-SD93E)	0000 10L	0000 7L	: :	: :	<u>0006 16L</u>	<u>0004 11L</u>	: :	: :	0010 20L	0015 22L
(For AJ-SD93P)	(For AJ-SD93E)												
0000 10L	0000 7L												
: :	: :												
<u>0006 16L</u>	<u>0004 11L</u>												
: :	: :												
0010 20L	0015 22L												
502 VITC POS-2	<p>This sets the position where the VITC signal is to be inserted.</p> <table style="width: 100%; border: none;"> <tr> <td style="text-align: center;">(For AJ-SD93P)</td> <td style="text-align: center;">(For AJ-SD93E)</td> </tr> <tr> <td style="text-align: center;">0000 10L</td> <td style="text-align: center;">0000 7L</td> </tr> <tr> <td style="text-align: center;">: :</td> <td style="text-align: center;">: :</td> </tr> <tr> <td style="text-align: center;"><u>0008 18L</u></td> <td style="text-align: center;"><u>0006 13L</u></td> </tr> <tr> <td style="text-align: center;">: :</td> <td style="text-align: center;">: :</td> </tr> <tr> <td style="text-align: center;">0010 20L</td> <td style="text-align: center;">0015 22L</td> </tr> </table> <p>Notes:</p> <ul style="list-style-type: none"> • The same line as the one used for the setup menu items No. 501 (VITC POS-1) and No. 662 (UMID POS) setting cannot be set. • The default settings are not restored even if the RESET button is pressed while holding down the SEARCH button. 	(For AJ-SD93P)	(For AJ-SD93E)	0000 10L	0000 7L	: :	: :	<u>0008 18L</u>	<u>0006 13L</u>	: :	: :	0010 20L	0015 22L
(For AJ-SD93P)	(For AJ-SD93E)												
0000 10L	0000 7L												
: :	: :												
<u>0008 18L</u>	<u>0006 13L</u>												
: :	: :												
0010 20L	0015 22L												
503 TCG REGEN	<p>This selects the signal to be regenerated when the time code generator (TCG) in the REGEN mode.</p> <p>0000 TC&UB : Both the time code and user bit are regenerated.</p> <p>0001 TC : Only the time code is regenerated.</p> <p>0002 UB : Only the user bit is regenerated.</p>												

No./Item	Description
505 EXT TC SEL	<p>This selects the time code to be used when an external time code is to be used.</p> <p>0000 LTC : The LTC of the TIME CODE IN connector is used.</p> <p>0001 VITC : The VITC of the input video signal or the timecode of the IEEE 1394 digital input signal is used.</p> <p>Note: Operation uses the VITC setting if AJ-YA93P is not installed.</p> <p>YA93P</p>
506 BINARY GP	<p>This sets the usage status of the user bit of the time code generated by the TCG.</p> <p>0000 000 : NOT SPECIFIED (character set not specified)</p> <p>0001 001 : ISO CHARACTER (8 bits character set based on ISO646, ISO2022)</p> <p>0002 010 : UNASSIGNED 1 (undefined)</p> <p>0003 011 : UNASSIGNED 2 (undefined)</p> <p>0004 100 : UNASSIGNED 3 (undefined)</p> <p>0005 101 : PAGE/LINE</p> <p>0006 110 : UNASSIGNED 4 (undefined)</p> <p>0007 111 : UNASSIGNED 5 (undefined)</p>
507 PHASE CORR	<p>This selects whether to control the phase correction of the LTC which is output from the TIME CODE OUT connector.</p> <p>0000 OFF : Phase correction control is not performed.</p> <p>0001 ON : Phase correction control is performed.</p> <p>YA93P</p>
508 TCG CF FLAG	<p>This selects whether the CF flag of the TCG is to ON.</p> <p>0000 OFF : CF flag is OFF.</p> <p>0001 ON : CF flag is ON.</p>
509 DF MODE (For AJ-SD93P)	<p>This selects the DF or NDF mode for CTL and TCG.</p> <p>0000 DF : The drop frame mode is used.</p> <p>0001 NDF : The non-drop frame mode is used.</p> <p>Note: DF/NDF switching is valid only when the CONTROL switch is set to LOCAL or the setup menu No. 001 (LOCAL ENA) is set to ENA.</p>

The underlined items indicates the initial setting.

YA93P This appears only when the optional board AJ-YA93P has been installed.

Setup menus (continued)

■ USER menu <TIME CODE>

No./Item	Description
510 TC OUT REF YA93P	<p>This is used to switch the phase of the time code, which is output from the TIME CODE OUT connector, for the external LTC input when the TCG switch is at the EXT position.</p> <p><u>0000 V OUT</u> : Time code is synchronized with output video signal.</p> <p><u>0001 TC_IN</u> : Time code is synchronized with external time code input.</p>
511 VITC OUT	<p>This selects how the VITC which is to be superimposed onto the output video signal is to be output.</p> <p><u>0000 SBC</u> : During recording: The input time code, which was selected by the setup menu No. 505 (EXT TC SEL) setting and TCG switch, is output as the VITC. During playback: The time code recorded in the SBC area is output as the VITC.</p> <p><u>0001 VAUX</u> : During recording: The time code detected from the input video signal is output as the VITC. During playback: The time code recorded in the VAUX area is output as the VITC.</p> <p>Notes:</p> <ul style="list-style-type: none"> • The time code detected from the input video signal is automatically recorded in the VAUX area while pictures are being recorded. • If Y PB PR, CMPST, or SDI is selected as the input signal, the VITC output during recording is a timecode superimposed on the input signal regardless of the above setting.
513 RUN MODE	<p>This sets the operation mode which is to make the internal time code generator advance.</p> <p><u>0000 REC</u> : The internal time code generator is advanced during recording.</p> <p><u>0001 FREE</u> : When the power is on, the internal time code generator is advanced regardless of the operation mode.</p>

No./Item	Description
514 VITC GEN	<p>This selects whether or not to record the internal time code generator value in the VAUX area.</p> <p><u>0000 OFF</u> : The internal time code generator value is not recorded in the VAUX area. When video signals on which the time code has been recorded are input, the time code of the input signals is recorded in the VAUX area.</p> <p><u>0001 ON</u> : The internal time code generator value is recorded in the VAUX area.</p>

SBC (sub code data) area:

This area is separate from the video and audio data area on the helical track. The time code complying with SMPTE/EBU standards is stored here. As with the conventional LTC (linear time code), the time code can be read even during rewinding or fast forwarding. It can also be read out when the tape has stopped.

VAUX (video auxiliary data) area:

This area is to be found in the video data area on the helical track. The additional information relating to the video data is stored here.

Note:

The time code and user bit are controlled during tape playback by the data which has been recorded in the SBC area. This means that all the data recorded in the SBC area alone is used as the data which is to be indicated on the counter display section in the middle of the front panel or in the superimposed display, or as the data which is to be transmitted to the editing controller or other unit.

The underlined items indicates the initial setting.

YA93P This appears only when the optional board AJ-YA93P has been installed.

Setup menus (continued)

■ USER menu <VIDEO>

No./Item	Description
600 INT SG	This selects the internal reference signal. 0001 BB : The black burst is generated. 0002 CB100 : 100% color bars are generated. 0003 CB75 : 75% color bars are generated.
602 V-MUTE SEL	This selects whether to mute the video output signals when a blank on the tape has been detected during playback. 0000 N-MUTE : No muting. (Freeze) 0001 LOW RF : Muting. (Set to gray.)
603 CC (F1) BLANK (For AJ-SD93P)	This selects ON or OFF for the closed caption signal of the first field. 0000 BLANK : Signal is forcibly blanked. 0001 THRU : Signal is not blanked.
604 CC (F2) BLANK (For AJ-SD93P)	This selects ON or OFF for the closed caption signal of the second field. 0000 BLANK : Signal is forcibly blanked. 0001 THRU : Signal is not blanked.
605 FREEZE SEL	This selects the freeze mode for still pictures. 0000 FIELD : Field freeze. 0001 FRAME : Frame freeze. Note: When frame freeze has been selected, the frame slow status is established with the slow setting.
609 EDH YA94G	This selects whether to superimpose EDH onto the SDI output signals. 0000 OFF : EDH is not superimposed. 0001 ON : EDH is superimposed.
610 PB/PR IN LV (For AJ-SD93P) YA93P	This selects the analog component input level. 0000 M II : M II level 0001 B-CAM : β -CAM level
614 PB/PR OUT LV (For AJ-SD93P) YA93P	This selects the analog component output level. 0000 M II : M II level 0001 B-CAM : β -CAM level

No./Item	Description
622 SETUP 25 (For AJ-SD93P)	For setting 7.5% setup processing to be performed on input and output signals in the DVCPRO (25 Mbps) mode. When the STOP button is pressed, operation is transferred to the sub-screen, and the setup level is set for each output. To return from the sub-screen, press the STOP button again.
Sub-screen	
00 CMPST IN YA93P	This selects the 7.5% setup processing for the input composite signal. 0000 THRU : The signal is recorded in its original form. 0001 CUT : The signal is recorded with the 7.5% setup removed.
01 CMPST OUT	This selects the 7.5% setup processing for the output composite signal. 0000 THRU : The signal is output in its original form. 0001 ADD : The signal is output with the 7.5% setup added. Note: Bear in mind the setting for sub-screen item No. 03 (CMPNT OUT) of setup menu item No. 622 (SETUP 25).
02 CMPNT IN YA93P YA94G	This selects the 7.5% setup processing for the input component signal. 0000 THRU : The signal is recorded in its original form. 0001 CUT : The signal is recorded with the 7.5% setup removed.
03 CMPNT OUT YA93P YA94G	This selects the 7.5% setup processing for the output composite, component and serial (digital) signal. 0000 THRU : The signal is output in its original form. 0001 CUT : The signal is output with the 7.5% setup removed. 0002 ADD : The signal is output with the 7.5% setup added.

The underlined items indicates the initial setting.

YA93P This appears only when the optional board AJ-YA93P has been installed.

YA94G This appears only when the optional board AJ-YA94G has been installed.

Setup menus (continued)

■ USER menu <VIDEO>

No./Item	Description
623 SETUP 50 (For AJ-SD93P)	For setting 7.5% setup processing to be performed on input and output signals in the DVCPRO50 (50 Mbps) mode. When the STOP button is pressed, operation is transferred to the sub-screen, and the setup level is set for each output. To return from the sub-screen, press the STOP button again.
Sub-screen	
00 CMPST IN YA93P	This selects the 7.5% setup processing for the input composite signal. 0000 THRU : The signal is recorded in its original form. 0001 CUT : The signal is recorded with the 7.5% setup removed.
01 CMPST OUT YA93P	This selects the 7.5% setup processing for the output composite signal. 0000 THRU : The signal is output in its original form. 0001 ADD : The signal is output with the 7.5% setup added. Note: Bear in mind the setting for sub-screen item No. 03 (CMPNT OUT) of setup menu item No. 623 (SETUP 50).
02 CMPNT IN YA93P YA94G	This selects the 7.5% setup processing for the input component signal. 0000 THRU : The signal is recorded in its original form. 0001 CUT : The signal is recorded with the 7.5% setup removed.
03 CMPNT OUT YA93P YA94G	This selects the 7.5% setup processing for the output composite, component and serial (digital) signal. 0000 THRU : The signal is output in its original form. 0001 CUT : The signal is output with the 7.5% setup removed. 0002 ADD : The signal is output with the 7.5% setup added.

No./Item	Description
624 CC REC (For AJ-SD93P) YA93P YA94G	For selecting whether to record the closed caption signals multiplexed on the input signals on the tape. 0000 OFF : No closed caption signal is recorded. 0001 ON : When a closed caption signal is detected from the selected input signal, it can be recorded. Note: If 1394 signals have been selected as the input signals using the INPUT SELECT button, the closed caption signals which have been multiplexed onto the input signals will be recorded on the tape regardless of the setting.
645 WIDE SELECT	This selects whether or not to record the wide-screen information on the tape. 0001 WIDE : The wide-screen information is not recorded on the tape. 0002 NORMAL : The wide-screen information is recorded on the tape. Note: If 1394 has been selected as the input signals using the INPUT SELECT button, the wide-screen information on the input signals will be recorded regardless of this menu's setting.
660 UMID REC	This selects whether or not to record the UMID information on the tape. 0000 OFF : UMID information is not recorded on the tape. 0001 ON : UMID information is recorded on the tape. Note: If 1394 has been selected as the input signals using the INPUT SELECT button, UMID will not be recorded even when it is set to ON unless the input signal can be detected.

The underlined items indicates the initial setting.

YA93P This appears only when the optional board AJ-YA93P has been installed.

YA94G This appears only when the optional board AJ-YA94G has been installed.

Setup menus (continued)

■ USER menu <VIDEO>

No./Item	Description														
661 UMID GEN	<p>This selects the basic UMID information to be recorded on the tape when ON has been selected as the setup menu item No. 660 (UMID REC) setting.</p> <p>0000 INT : Newly created basic UMID information of this unit is always recorded.</p> <p>0001 EXT : The basic UMID information of the input signals is recorded. Newly created basic UMID information of this unit is recorded if there is no basic UMID information on the input signals.</p> <p>Note: The source pack (of the UMID information) of the input signal will be recorded on the tape, regardless of this menu's setting.</p>														
662 UMID POS	<p>This sets the line on which the UMID information is to be superimposed.</p> <table style="width: 100%; border: none;"> <tr> <td style="width: 50%; text-align: center;">(For AJ-SD93P)</td> <td style="width: 50%; text-align: center;">(For AJ-SD93E)</td> </tr> <tr> <td style="text-align: center;">0000 BLANK</td> <td style="text-align: center;">0000 BLANK</td> </tr> <tr> <td style="text-align: center;">0001 12L</td> <td style="text-align: center;">0001 8L</td> </tr> <tr> <td style="text-align: center;">: :</td> <td style="text-align: center;">: :</td> </tr> <tr> <td style="text-align: center;">0006 17L</td> <td style="text-align: center;">0010 17L</td> </tr> <tr> <td style="text-align: center;">: :</td> <td style="text-align: center;">: :</td> </tr> <tr> <td style="text-align: center;">0008 19L</td> <td style="text-align: center;">0015 22L</td> </tr> </table> <p>Notes:</p> <ul style="list-style-type: none"> • The line selected for the setup menu item No. 501 (VITC POS-1) and No. 502 (VITC POS-2) settings cannot be selected for this item. • The default settings are not restored even if the RESET button is pressed while holding down the SEARCH button. 	(For AJ-SD93P)	(For AJ-SD93E)	0000 BLANK	0000 BLANK	0001 12L	0001 8L	: :	: :	0006 17L	0010 17L	: :	: :	0008 19L	0015 22L
(For AJ-SD93P)	(For AJ-SD93E)														
0000 BLANK	0000 BLANK														
0001 12L	0001 8L														
: :	: :														
0006 17L	0010 17L														
: :	: :														
0008 19L	0015 22L														

YA94G

■ USER menu <AUDIO>

No./Item	Description
701 CH1 IN LV	<p>This selects the audio input (CH1) reference level switching.</p> <p>0000 4dB 0001 <u>0dB</u> 0002 -20dB</p> <p>YA93P</p>
702 CH2 IN LV	<p>This selects the audio input (CH2) reference level switching.</p> <p>0000 4dB 0001 <u>0dB</u> 0002 -20dB</p> <p>YA93P</p>
703 CH3 IN LV	<p>This selects the audio input (CH3) reference level switching.</p> <p>0000 4dB 0001 <u>0dB</u> 0002 -20dB</p> <p>YA93P</p>
704 CH4 IN LV	<p>This selects the audio input (CH4) reference level switching.</p> <p>0000 4dB 0001 <u>0dB</u> 0002 -20dB</p> <p>YA93P</p>
706 CH1 OUT LV	<p>This selects the audio output (CH1) reference level switching.</p> <p>0000 4dB 0001 <u>0dB</u> 0002 -20dB</p> <p>YA93P</p>
707 CH2 OUT LV	<p>This selects the audio output (CH2) reference level switching.</p> <p>0000 4dB 0001 <u>0dB</u> 0002 -20dB</p> <p>YA93P</p>
708 CH3 OUT LV	<p>This selects the audio output (CH3) reference level switching.</p> <p>0000 4dB 0001 <u>0dB</u> 0002 -20dB</p> <p>YA93P</p>
709 CH4 OUT LV	<p>This selects the audio output (CH4) reference level switching.</p> <p>0000 4dB 0001 <u>0dB</u> 0002 -20dB</p> <p>YA93P</p>

The underlined items indicates the initial setting.

YA93P This appears only when the optional board AJ-YA93P has been installed.

YA94G This appears only when the optional board AJ-YA94G has been installed.

Setup menus (continued)

■ USER menu <AUDIO>

No./Item	Description
722 REC CH1 YA93P YA94G	<p>This selects the input signal to be recorded on the audio CH1 track.</p> <p><u>0000</u> CH1 : Audio input CH1 signal.</p> <p><u>0001</u> CH2 : Audio input CH2 signal.</p> <p><u>0002</u> CH1+2 : Mixed audio input CH1 and CH2 signal.</p>
723 REC CH2 YA93P YA94G	<p>This selects the input signal to be recorded on the audio CH2 track.</p> <p><u>0000</u> CH1 : Audio input CH1 signal.</p> <p><u>0001</u> CH2 : Audio input CH2 signal.</p> <p><u>0002</u> CH1+2 : Mixed audio input CH1 and CH2 signal.</p>
724 REC CH3 YA93P YA94G	<p>This selects the input signal to be recorded on the audio CH3 track.</p> <p><u>0000</u> CH3 : Audio input CH3 signal.</p> <p><u>0001</u> CH4 : Audio input CH4 signal.</p> <p><u>0002</u> CH3+4 : Mixed audio input CH3 and CH4 signal.</p>
725 REC CH4 YA93P YA94G	<p>This selects the input signal to be recorded on the audio CH4 track.</p> <p><u>0000</u> CH3 : Audio input CH3 signal.</p> <p><u>0001</u> CH4 : Audio input CH4 signal.</p> <p><u>0002</u> CH3+4 : Mixed audio input CH3 and CH4 signal.</p>
727 PB FADE	<p>This selects the processing method for the audio edit points (IN point, OUT point) during playback.</p> <p><u>0000</u> AUTO : According to the status during recording.</p> <p><u>0001</u> CUT : Forced CUT</p> <p><u>0002</u> FADE : Forced FADE</p>
728 EMBEDDED AUD YA94G	<p>This selects whether to superimpose the audio data onto the SDI output.</p> <p><u>0000</u> OFF : Data is not superimposed.</p> <p><u>0001</u> ON : Data is superimposed.</p>

No./Item	Description
734 MONI SEL INH	<p>This selects whether the operation of the MONITOR SELECT button on the front panel is to be enabled or disabled.</p> <p><u>0000</u> OFF : Operation is enabled.</p> <p><u>0001</u> ON : Operation is disabled.</p> <p><u>0002</u> ON1 : Operation is disabled in the FULL display mode and enabled only in the FINE display mode.</p>
750 DV PB ATT	<p>This selects the audio output level during DV playback.</p> <p><u>0000</u> OFF : The audio output level is not attenuated.</p> <p><u>0001</u> ON : The audio output level is attenuated (reduced).</p>
751 REC PT MUTE	<p>This selects whether to mute the sound where recordings are joined during DV/DVCAM</p> <p><u>0000</u> OFF : The sound is not muted.</p> <p><u>0001</u> ON : The sound is muted.</p>

The underlined items indicates the initial setting.

YA93P This appears only when the optional board AJ-YA93P has been installed.

YA94G This appears only when the optional board AJ-YA94G has been installed.

Setup menus (continued)

■ USER menu <V BLANK>

No./Item	Description																																				
802 TELETEXT SEL (For AJ-SD93P) YA93P YA94G	<p>For selecting the type of teletext signals to be recorded.</p> <p>0000 MOJI : MOJI system 0001 NABTS : NABTS system Note: Signals like VITC signals are often mistakenly detected as teletext signals when the NABTS system has been selected. If this happens, select MANU as the setting for setup menu No. 803 (TELETEXT DET), then select the line for teletext signals.</p>																																				
803 TELETEXT DET YA93P YA94G	<p>For selecting the method used to detect the lines in which the teletext signals are to be recorded.</p> <p>0000 OFF: The teletext signals are not recorded. 0001 AUTO : The teletext signals are automatically detected 0002 MANU : The lines in which the teletext signals are to be recorded are selected and set. Notes: • The number of lines in which the teletext signals can be recorded differs depending on the setup menu item No.660 (UMID REC) setting. (See "Number of lines which can be set for teletext".) • When setting "MANU" is selected and the STOP button is pressed, operation transfers to the sub-screen, and the number of recording lines can be selected. To return from the sub-screen, press the STOP button again.</p>																																				
Sub-screen																																					
(For AJ-SD93P) 00 REC LINE1 : 12 REC LINE13 (For AJ-SD93E) 00 REC LINE1 : 14 REC LINE15	<p>For selecting the lines in which the teletext signals are to be recorded.</p> <table border="0"> <tr> <td>(For AJ-SD93P)</td> <td>(For AJ-SD93E)</td> </tr> <tr> <td>0000 OFF</td> <td>0000 OFF</td> </tr> <tr> <td>0002 11&274</td> <td>0001 7&320</td> </tr> <tr> <td>0003 12&275</td> <td>0002 8&321</td> </tr> <tr> <td>0004 13&276</td> <td>0003 9&322</td> </tr> <tr> <td>0005 14&277</td> <td>0004 10&323</td> </tr> <tr> <td>0006 15&278</td> <td>0005 11&324</td> </tr> <tr> <td>0007 16&279</td> <td>0006 12&325</td> </tr> <tr> <td>0008 17&280</td> <td>0007 13&326</td> </tr> <tr> <td>0009 18&281</td> <td>0008 14&327</td> </tr> <tr> <td>0010 19&282</td> <td>0009 15&328</td> </tr> <tr> <td>0011 20&283</td> <td>0010 16&329</td> </tr> <tr> <td>0012 21&284</td> <td>0011 17&330</td> </tr> <tr> <td>0013 22</td> <td>0012 18&331</td> </tr> <tr> <td></td> <td>0013 19&332</td> </tr> <tr> <td></td> <td>0014 20&333</td> </tr> <tr> <td></td> <td>0015 21&334</td> </tr> <tr> <td></td> <td>0016 22</td> </tr> </table>	(For AJ-SD93P)	(For AJ-SD93E)	0000 OFF	0000 OFF	0002 11&274	0001 7&320	0003 12&275	0002 8&321	0004 13&276	0003 9&322	0005 14&277	0004 10&323	0006 15&278	0005 11&324	0007 16&279	0006 12&325	0008 17&280	0007 13&326	0009 18&281	0008 14&327	0010 19&282	0009 15&328	0011 20&283	0010 16&329	0012 21&284	0011 17&330	0013 22	0012 18&331		0013 19&332		0014 20&333		0015 21&334		0016 22
(For AJ-SD93P)	(For AJ-SD93E)																																				
0000 OFF	0000 OFF																																				
0002 11&274	0001 7&320																																				
0003 12&275	0002 8&321																																				
0004 13&276	0003 9&322																																				
0005 14&277	0004 10&323																																				
0006 15&278	0005 11&324																																				
0007 16&279	0006 12&325																																				
0008 17&280	0007 13&326																																				
0009 18&281	0008 14&327																																				
0010 19&282	0009 15&328																																				
0011 20&283	0010 16&329																																				
0012 21&284	0011 17&330																																				
0013 22	0012 18&331																																				
	0013 19&332																																				
	0014 20&333																																				
	0015 21&334																																				
	0016 22																																				

The underlined items indicates the initial setting.

YA93P This appears only when the optional board AJ-YA93P has been installed.

YA94G This appears only when the optional board AJ-YA94G has been installed.

No./Item	Description
804 BLANK LINE	<p>This turns the blanking ON or OFF in the vertical blanking period of the video output signals.</p> <p>0000 BLANK : Blanking is effected forcibly for all lines. 0001 THRU : No blanking is effected for any of the lines. 0002 MANU : Blanking ON or OFF is selected for each line. Note: When setting "MANU" is selected and the STOP button is pressed, operation transfers to the sub-screen, and ON or OFF can be selected for each line. To return from the sub-screen, press the STOP button again.</p>
Sub-screen	
(For AJ-SD93P) 00 LINE 10&273 : 11 LINE 21&284 (For AJ-SD93E) 00 LINE 7&320 : 15 LINE 22&335	<p>0000 BLANK : Blanking is forcibly effected. 0001 THRU : No blanking is effected.</p>

• Number of lines which can be set for teletext
For AJ-SD93P:

No.660: UMID REC setting	Number of lines which can be set	
	Record/playback format, 50 Mbps	Record/playback format, 25 Mbps
OFF	10	13
ON	9	10

For AJ-SD93E:

No.660: UMID REC setting	Number of lines which can be set	
	Record/playback format, 50 Mbps	Record/playback format, 25 Mbps
OFF	15	14
ON	12	12

•The teletext signals which are played back do not satisfy the ITU-R BT.653 teletext standard perfectly.

Setup menus (continued)

■ USER menu <DIF>

No./Item	Description
880 DIF SPEED	<p>This sets the transfer rate of the IEEE 1394 digital interface output.</p> <p><u>0000</u> <u>S100</u> : 100 Mbps 0001 S200 : 200 Mbps 0002 S400 : 400 Mbps</p>
881 DIF TYPE (For AJ-SD93P)	<p>This sets the format when the IEEE 1394 digital signals are output.</p> <p><u>0000</u> <u>DVCPRO</u> : The signals are forcibly output in the DVCPRO format.</p> <p>0001 DV : The signals are forcibly output in the DV format.</p> <p><u>0002</u> <u>AUTO</u> : During playback, the playback tape format takes priority. During EE, the setting in setup menu No. 012 (SYS FORMAT) takes priority.</p> <p>Note: If the format during playback and EE is DVPRO50, the signals are output in DVPRO50 format regardless of this menu setting.</p>
882 DIF IN CH	<p>This sets the IEEE 1394 digital input channel.</p> <p><u>0000</u> 0 : : 0063 63</p> <p>0-63: These channels are fixed to assigned values.</p> <p><u>0064</u> <u>AUTO</u> : The channel is not fixed to assigned values. When the power is turned on, the input channel is initialized to 63.</p>
883 DIF OUT CH	<p>This sets the IEEE 1394 digital output channel.</p> <p><u>0000</u> 0 : : 0063 63</p> <p>0-63: These channels are fixed to assigned values.</p> <p><u>0064</u> <u>AUTO</u> : The channel is not fixed to assigned values. When the power is turned on, the output channel is initialized to 63.</p>
886 DIF CONFIG	<p>This menu item is used to support future expansion. Normally, "DFLT" is used as the setting.</p> <p><u>0000</u> <u>DFLT</u> 0001 1 : : 0255 255</p>

No./Item	Description
889 DIF AUD IN (For AJ-SD93P)	<p>This selects the channels to be used for recording on the tape when DV format data with audio signals in the 4CH mode are to be input and then recorded on a DVCPRO tape.</p> <p><u>0000</u> <u>CH1&2</u> : Received DV format data CH1 and CH2 are selected.</p> <p>0001 CH3&4 : Received DV format data CH3 and CH4 are selected.</p>
890 DIF AUD OUT	<p>(For AJ-SD93P) This selects the channels when a DV tape with audio signals in the 4CH mode is played and the signals are output in the DVCPRO format or when LOCK48 has been selected as the setup menu item No.891 (DIF DV AUDIO) setting.</p> <p>(For AJ-SD93E) When setup menu No. 891 (DIF DV AUDIO) is set to LOCK48, this selects the output channels for playing back the DV tape with audio signals in 4CH mode.</p> <p><u>0000</u> <u>CH1&2</u> : DV tape CH1 and CH2 are selected.</p> <p>0001 CH3&4 : DV tape CH3 and CH4 are selected.</p>
891 DIF DV AUDIO	<p>This sets the forced audio mode conversion when a DV tape is played and its signals are output in the DV format.</p> <p><u>0000</u> <u>THRU</u> : Normal (through)</p> <p>0001 LOCK : The audio mode is forcibly converted to the LOCK mode. (The frequency is not converted.)</p> <p>0002 LOCK48 : The audio mode is forcibly converted to 48 kHz/2CH/LOCK.</p>

The underlined items indicates the initial setting.

Setup menus (continued)

■ USER menu <MENU>

No./Item	Description
A00 LOAD	<p>This selects the user file whose contents will be loaded into USER1.</p> <p>0000 USER2 : The USER2 file contents are loaded.</p> <p>0001 USER3 : The USER3 file contents are loaded.</p> <p>0002 USER4 : The USER4 file contents are loaded.</p> <p>0003 USER5 : The USER5 file contents are loaded.</p> <p>Note: Pressing the MENU button after loading displays a confirmation screen. Pressing the PLAY button stores the setting values. The setting values are not changed if the STOP button is pressed.</p>
A01 SAVE	<p>This selects the user file into which the USER1 settings will be saved.</p> <p>0000 USER2 : The settings are saved in USER2.</p> <p>0001 USER3 : The settings are saved in USER3.</p> <p>0002 USER4 : The settings are saved in USER4.</p> <p>0003 USER5 : The settings are saved in USER5.</p> <p>0004 LOCKED : This display appears when all the user files are in the change prohibit status.</p> <p>Notes:</p> <ul style="list-style-type: none"> • User files whose status have been set to change prohibit cannot be selected. • When all the user files are in the change prohibit status, the "LOCKED" display appears and the contents cannot be saved.

Notes:

- No. A00 (LOAD), No. A01 (SAVE) and No. A02 (P. ON LOAD) are the menu items which can be set only for USER1. They are not displayed with the USER2 – USER5 files.
- No. A03 (MENU LOCK) is the menu item which can be set only for the USER2 – USER5 files. It is not displayed with USER1.

No./Item	Description
A02 P. ON LOAD	<p>This loads the contents of the selected user file into USER1 and it starts operation with the USER1 settings when the power is turned on.</p> <p>0000 OFF : Operation is started with the settings of the previously set user file.</p> <p>0001 USER2 : The contents of USER2 are loaded into USER1 and operation is started with the USER1 settings.</p> <p>0002 USER3 : The contents of USER3 are loaded into USER1 and operation is started with the USER1 settings.</p> <p>0003 USER4 : The contents of USER4 are loaded into USER1 and operation is started with the USER1 settings.</p> <p>0004 USER5 : The contents of USER5 are loaded into USER1 and operation is started with the USER1 settings.</p>
A03 MENU LOCK	<p>This selects whether to set or release the user file (USER2 – USER5) lock mode.</p> <p>0000 OFF : The lock is released (changes can be made).</p> <p>0001 ON : The lock is set (changes are prohibited).</p> <p>Note: The lock cannot be set for USER1.</p>
A04 PF1 ASSIGN	The setup menu item is stored to the PF1 button.
A05 PF2 ASSIGN	The setup menu item is stored to the PF2 button.
A06 PF3 ASSIGN	The setup menu item is stored to the PF3 button.

The underlined items indicates the initial setting.

Time code/user bit

Time code

The time code is used when the time code signal generated by the time code generator (time code signal generator) is to be recorded on the tape, its values are to be read by the time code reader (time code signal reader), and the absolute position of the tape is to be displayed in increments of hours, minutes, seconds and frames.

The time code is written in the sub-code area (data area) of the helical track. The VTR's playback speed can be read from the stop mode to slow-motion playback up to high-speed play (approx. 50 a normal speed approx. 100 a when using DVCPRO tape).

The time code values are indicated using the display and superimpose functions.

TCR	00	:	07	:	04	:	24
	↑		↑		↑		↑
	Hours		Minutes		Seconds		Frames

User bit

"User bit" refers to the 32-bit (8-digit) data frame among the time code signals which has been released to users. It enables operator numbers values to be recorded.

The alphanumeric characters which can be used for the user bit are the figures 0 to 9 and the letters A to F.

Setting the internal time code

- (1) Set the VTR to stop mode.
- (2) Select "TC" using the COUNTER button.
- (3) Set the run mode for the time code generator using setup menu No. 513 (RUN MODE).

REC:

The internal time code generator is advanced during recording.

FREE:

When the power is on, the internal time code generator is advanced regardless of the operation mode.

- (4) Set the TCG switch to REGEN mode.

REGEN:

In this mode, the continuity of the original time code is maintained.

A more detailed setting can be performed using setup menu No. 503 (TCG REGEN).

PRESET:

In this mode, recording is commenced from the value which was set by the TC PRESET button.

- (5) To preset the time code or user bit, take the following steps.

- ① Set the TCG switch to "PRESET."
- ② Select "TC" or "UB" using the COUNTER button.
- ③ When the TC PRESET button is pressed, operation is transferred to the setting mode, and the setting digits start flashing on the counter display.
- ④ Operate the joystick, and set the preset value.
Left, right → for moving between digits; up, down → for changing the setting
 - When the RESET button is pressed, the preset value is reset to zero.
- ⑤ The preset value is set by pressing the TC PRESET button.

Setting the external time code

- (1) Set the VTR to stop mode.
- (2) Select "TC" using the COUNTER button.
- (3) Set the TCG switch to EXT. (External time code selection)
- (4) The following settings can be selected with setup menu No. 505 (EXT TC SEL). (only when AJ-YA93P is installed).

LTC:

The LTC signal input to the TIME CODE IN connector (BNC) on the rear panel is recorded as time code.

Note:

The LTC must be synchronized with the video signal.

The AJ-YA93P analog I/O board option is required.

VITC:

The VITC of the input video signal or time code on IEEE 1394 is recorded.

Reproducing the time code/user bit

- (1) Set the VTR to stop mode.
- (2) Select "TC" or "UB" using the COUNTER button.
- (3) Press the PLAY button.

Playback starts and the time code is shown on the display.

When the SUPER switch is set to ON, the time code value is superimposed on the video signals from the VIDEO MON connector.

Note:

When the time code signal cannot be read, the time code is automatically interpolated by the CTL signal. The display appears as shown below.

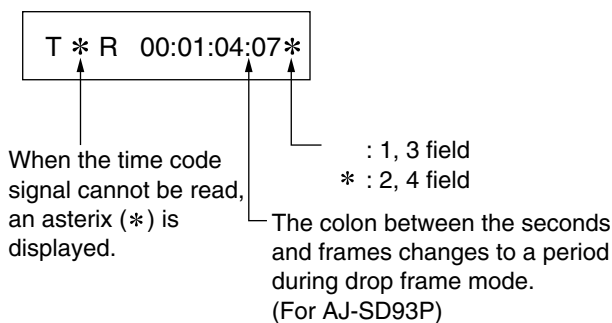

Time code/user bit (continued)

Timecodes recorded by this product

TCG switch	Setup menu No. 505 EXT TC SEL	Setup menu No. 514 VITC GEN	Selected video input signal	Recorded timecode	
				SBC area	VAUX area
INT (REGEN/ PRESET)	---	OFF	1394	Internal TCG value	Timecode on IEEE 1394 digital input (VAUX area)
		Y PB PR/ CMPST/SDI			VITC on input video signal * 3
		ON	---	Internal TCG value	
EXT	LTC	OFF	1394	Timecode from TIME CODE IN connector input * 1	Timecode on IEEE 1394 digital input (VAUX area)
		Y PB PR/ CMPST/SDI			VITC on input video signal * 3
	ON	---	Timecode from TIME CODE IN connector input * 1		
	VITC	OFF	1394	Timecode on IEEE 1394 digital input (SBC area)	Timecode on IEEE 1394 digital input (VAUX area)
		Y PB PR/ CMPST/SDI		VITC on input video signal * 2	VITC on input video signal * 3
		ON	1394	Timecode on IEEE 1394 digital input (SBC area)	
		Y PB PR/ CMPST/SDI	VITC on input video signal * 2		

* 1: The internal TCG value is used when the signal cannot be detected from the TIME CODE IN connector input.

* 2: The internal TCG value is used when the VITC cannot be detected on the input video signal.

* 3: Nothing is recorded if the VITC cannot be detected on the input video signal.

Superimpose screen

The control signals, time code, etc. are displayed using abbreviations.

TV monitor

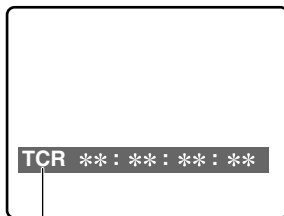

Abbreviations:

CTL : Control signal count value

TCR : Time code data recorded in the SBC area

TCR. : Time code data recorded in the VAUX area

UBR : User bit data recorded in the SBC area

UBR. : User bit data recorded in the VAUX area

TCG : Time code data of the time code generator

UBG : User bit data of the time code generator

Note:

[T * R], [T * R.], [U * R] or [U * R.] is displayed when the data has not been read correctly from the tape.

Characters displayed

The background of characters superimposed on the display can be changed using setup menu No. 011 (CHARA TYPE).



TV monitor

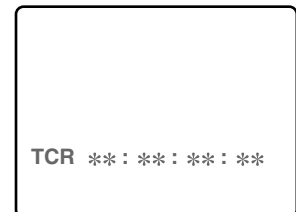

TV monitor

Display position

The position of the characters superimposed on the display can be changed using setup menus No. 009 (CHARA H-POS) and No. 010 (CHARA V-POS).



TV monitor



TV monitor

Operation mode

The VTR's operation mode can also be displayed using setup menu No. 008 (DISPLAY SEL).



TV monitor

VTR operation mode

Video head cleaning

This unit is equipped with an auto head cleaning function which automatically reduces the amount of dirt on the video heads. However, in order to maximize the unit's reliability, it is recommended that the video heads be cleaned as and when appropriate.

For further details on how to actually clean the heads, consult with one of our service companies or with your dealer.

Condensation

Condensation occurs due to the same principle involved when droplets of water form on a window pane of a heated room. It occurs when the unit or tape is moved between places where the temperature or humidity varies greatly or when, for instance:

- It is moved to a very humid place full of steam or a room immediately after it has been heated up.
- It is suddenly moved from a cold location to a hot or humid location.

When moving the unit to locations such as these, leave it standing for about 10 minutes rather than switching on the power immediately. If condensation occurs in the unit, "E-20" will flash on the counter display and the cassette will be automatically ejected.

Leave the unit with the power on until "E-20" is cleared from the display.

Maintenance

Before starting any maintenance work, switch the power to OFF and, holding the plug, unplug the cord from the socket.

Use a soft cloth to clean the outside of the unit.

For stubborn dirt or stains, wipe the unit with a cloth that has been lightly dampened with well-diluted kitchen detergent and wrung out thoroughly.

After wiping off the dirt with the damp cloth, finish it off with a dry cloth.

Note:

Do not use alcohol, benzene, thinners or any other solvents as they may affect the color of external parts or damage the unit's coating.

Error messages

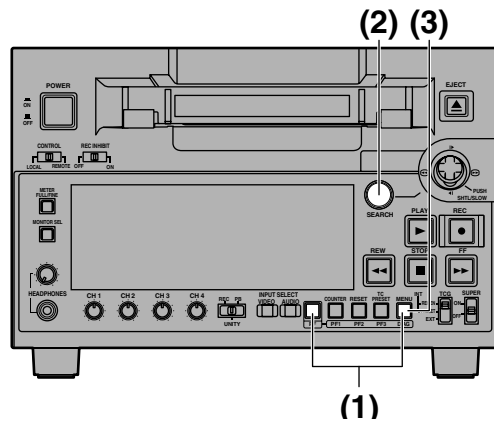

When a warning occurs in this unit, the error number is indicated on the counter display.
 Open the DIAG menu to display a description of the error on the counter display or monitor TV.
 When a operational malfunction has occurred in the unit, the error number flashes on the counter display.

■ DIAG menu

This displays the VTR information.
 The VTR information includes the warning information, hours meter (usage time) information and UMID information.
 The DIAG menu appears on the TV monitor when the VIDEO MON connector on the rear panel is connected to the TV monitor.

■ Displaying the “HOURS METER” information

When the joystick is moved up or down, the cursor (*) moves, and a description of the item where the cursor is located is shown on the counter display.

■ Displaying the DIAG menu

(1) Press the MENU button while holding down the PF button.

The DIAG menu screen appears on the TV monitor, and a message appears on the counter display.

(2) Press the SEARCH button.

Each time this button is pressed, the display changes by one step in the following sequence: “WARNING” → “HOURS METER” → “UMID INFO” → “DIF STATUS1” → “DIF STATUS2.”

(3) When the MENU button is pressed again, the original display is restored.



NO.	Item	Description
Ser	* * * * *	Displays the unit's serial No.
H00	OPERATION	Displays the time that the power has been supplied in one-hour units.
H01	DRUM RUN	Displays the time that the drum has been rotating in one-hour units.
H02	TAPE RUN	Displays the duration for which the tape has been running in the FF, REW, PLAY, SEARCH (JOG, SLOW, SHTL) and REC modes (but not in the JOG, SLOW and SHTL STILL modes) in 1-hour increments.
H03	THREADING	The number of times for threading (loading)/ unthreading (unloading) is displayed in single units.
H04	F LOADING	Displays the number of times front loading has been performed in single units.
H11	DRUM RUNr	Displays the time that the drum has been rotating in one-hour units. (Can be reset)
H12	TAPE RUNr	Displays the duration for which the tape has been running in the FF, REW, PLAY, SEARCH (JOG, SLOW, SHTL) and REC modes (but not in the JOG, SLOW and SHTL STILL modes) in 1-hour increments. (This item can be reset.)
H13	THREADINGr	The number of times for threading (loading)/ unthreading (unloading) is displayed in single units. (Can be reset)
H14	F LOADINGr	Displays the number of times front loading has been performed in single units. (Can be reset)
H30	POWER ON	The number of times the power has been turned on is displayed in single units.

Notes:

- The resettable items in the “HOURS METER” information are reset by the dealer when maintenance work is performed.
- No operations can be performed using the SEARCH button or the joystick while the DIAG menu is displayed.

Error messages (continued)

If "T&S&M" is selected in the setup menu No. 008 (DISPLAY SEL), a message appears in the modedisplay whenever a warning or error occurs. When multiple events occur, the event with the highest priority is displayed.

Priority	Display	Description
High   Low	Error messages (See error message table)	When an operational malfunction has occurred in the unit, the error number flashes and the error message is indicated on the counter display.
	INT SG	When SG has been selected as the input signal by the INPUT SELECT button, the "INT SG" display will appear for the first two seconds at the start of operation (E-E mode) when the REC button is pressed.
	NO INPUT	If there are no input signals--with the exception of the analog audio signals--supplied to the connectors selected by the INPUT SELECT button, the "NO INPUT" display will appear for the first two seconds at the start of operation (E-E mode) when the REC button is pressed.
	Warning messages (See error message table)	When a warning occurs in this unit, the error number and warning message are indicated on the counter display. When multiple warnings occur, the warning with the highest priority is displayed.

■ UMID information display

This is displayed when UMID information is present on the input signal in E-E mode.

This lamp lights during tape playback when UMID information has been recorded on the tape. "NO-INFO" is displayed when there is no UMID information.

Display	Description
MATNO	Material number
COPY	Instance number (No. of copies)
OWNR	Country, organization, user
POS	Reception status from GPS satellites when recording spatial coordinates (height above sea level, longitude and latitude): HOLD : No reception from any satellite 2D : Reception possible, but number of satellites is insufficient. Height above sea level will not be accurate. 3D : Good reception
DATE	Date
TIME	UTC (Coordinated Universal Time) and time difference with UTC

Error messages (continued)

■ Displaying the warning information

- A warning message appears when a warning has occurred. "NO WARNING" appears when a warning has not occurred.
- When more than one warning has occurred simultaneously, move the joystick up or down to check the description of each warning.

■ Warning messages

Priority	Monitor display	Description	Corrective action	VTR operation
High ↑ ↓ (Low)	E-04 (UNKNOWN SIG)	This appears when the signals supplied from the IEEE 1394 digital interface are not DVCPRO/DV format signals.	Check that the 1394 input has been connected properly.	No recording operations are possible.
	E-11 (NOT 1x 25M SIG)	This appears when the signals supplied from the IEEE 1394 digital interface are not DVCPRO/DV (25 Mbps) format 1x transfer signals.	Check the 1394 input signals.	No recording operations are possible.
	E-12 (NOT 1x 50M SIG)	This appears when the signals supplied from the IEEE 1394 digital interface are not DVCPRO50 (50 Mbps) format 1x transfer signals.	Check the 1394 input signals.	No recording operations are possible.
	E-16 (INVALID VIDEO SIG)	This appears when the compressed video signals supplied from the IEEE 1394 digital interface are irregular signals. • This warning appears only during recording operations. In such cases, no signals are recorded on the tape, and only erasure of existing signals is performed.	Check the 1394 input signals. It is possible that playback signals of an unrecorded tape are being input.	Operation cannot be continued.
	E-17 (INVALID AUDIO SIG)	This appears when the audio signals supplied from the IEEE 1394 digital interface are irregular signals. • This warning appears only during recording operations. In such cases, the signals are recorded with the audio signals muted.	Check the 1394 input signals. It is possible that signals other than 1x playback signals are being input from a VTR or other device.	Operation cannot be continued.
	E-18 (INVALID TC SIG)	This appears when the time code information supplied from the IEEE 1394 digital interface is irregular information. • This warning appears only during recording operations. In such cases, the internally generated time code is recorded.	Check the time code of the device which is supplying the time code.	Operation cannot be continued.
	E-92 (1394 INITIAL ERROR)	This appears when the connection status of the IEEE 1394 digital interface is irregular.	If a loop-through format has been adopted for the cable connections, reconnect each of the cables on a 1:1 basis. If such a format has not been adopted, set the POWER switch to OFF and then back to ON.	Signal input and output through the IEEE 1394 digital interface is stopped.
	E-10 (FAN STOP)	This appears when the fan motor has shut down.	Check the fan for foreign matter.	Operation continues.
	E-09 (NO RF)	This appears when a blank section lasting for more than one second on the tape has been detected during playback. A blank section is identified as such when all the following conditions are met: • There are no output signals from any of the heads. • The playback data cannot be read. • There is no CTL signal (DV/DVCAM tapes excluded).	Check the tape. It is possible that an unrecorded tape has been loaded.	Operation continues.
E-00 (SERVO NOT LOCKED)	This appears when the servo is not locked for three or more seconds during playback or recording.	Check the tape. It is possible that a tape recorded by a system other than 525/60 has been loaded.	Operation continues.	

Error messages (continued)

Priority	Monitor display	Description	Corrective action	VTR operation
↓ Low	E-01 (LOW RF)	This appears when an envelope level approximately one-third of the normal level has been detected for more than one second during playback or recording.	Clean the video heads.	Operation continues.
	E-02 (HIGH ERROR RATE)	This appears when the error rate has increased to the extent that correction or interpolation was applied to either the video or audio playback signals.	Clean the video heads.	Operation continues.

■ Error messages

Monitor display	Description	Corrective action	VTR operation
E-20 DEW	<p>If condensation is detected, the error number flashes and the unit transfers to eject mode. The drum rotates after the cassette is ejected to eliminate the condensation.</p> <p>Once the unit is released from condensation status, the error message display is cleared and the VTR is able to be used.</p> <ul style="list-style-type: none"> • If condensation is detected in the eject mode, the drum starts rotating as soon as it is detected. • If condensation is detected when the cassette has been inserted, the drum rotation is stopped, and after the tape is ejected, the drum starts rotating. 	Leave the power on and wait.	EJECT
E-29 FRONT LOAD MOTOR	<p>The unit switches to eject mode and if the cassette fails to move up within 6 seconds, this error number flashes on the display.</p> <p>Note: If the cassette does not move down inside the machine even when 6 seconds have elapsed since the cassette was inserted, the VTR is transferred to the eject mode.</p>	Set the POWER switch to OFF and then to ON again.	STOP
E-31 LOADING MOTOR	<p>If the unloading operation is not completed within 6 seconds, this error number flashes on the display.</p> <p>Note: When the loading operation is not completed within 6 seconds, the VTR is transferred to the eject (unloading) mode.</p>	Set the POWER switch to OFF and then to ON again.	STOP
E-35 SERVO CONTROL ERROR	If there is no response from the servo microcomputer for 1 second or more, this error number flashes on the display.	Set the POWER switch to OFF and then to ON again.	STOP
E-37 SERVO COMM ERROR	If 10 seconds or more elapses and the servo microcomputer has not followed orders issued by the system control microcomputer, this error number flashes on the display.	Set the POWER switch to OFF and then to ON again.	STOP
E-51 FRONT LOAD ERROR	If the take-up reel rotates without engaging for a specific period of time during the start or end processing operation while loading is underway (half position), this error number flashes on the display.	Set the POWER switch to OFF and then to ON again.	STOP

Error messages (continued)

Monitor display	Description	Corrective action	VTR operation
E-52 W-UP REEL NOT ROTA	If the take-up reel fails to take up the tape while the tape is traveling in the state where the total amount of the tape has not yet been detected after the cassette was inserted, this error number flashes on the display.	Set the POWER switch to OFF and then to ON again.	STOP
E-53 WINDUP ERROR	If there is an abnormally large discrepancy between the amount of tape taken up by the take-up reel and the amount of tape supplied by the supply reel while the tape is traveling after the total amount of the tape begins to be detected, this error number flashes on the display.	Set the POWER switch to OFF and then to ON again.	STOP
E-55 UNLOAD ERROR	If the tape has not been taken up during unloading, this error number flashes on the display.	Set the POWER switch to OFF and then to ON again.	STOP
E-57 S-FF/REW TIMEOVER	If the start or end processing operation is not completed, this error number flashes on the display.	Set the POWER switch to OFF and then to ON again.	STOP
E-59 DRUM ROTA TOO SLOW	If the cylinder motor speed is abnormally low, this error number flashes on the display.	Set the POWER switch to OFF and then to ON again.	STOP
E-60 DRUM ROTA TOO FAST	If the cylinder motor speed is abnormally high, this error number flashes on the display.	Set the POWER switch to OFF and then to ON again.	STOP
E-61 CAP ROTA TOO SLOW	If the capstan motor speed is abnormally low, the error number flashes on the display.	Set the POWER switch to OFF and then to ON again.	STOP
E-64 S REEL ROTA TOO FAST	If the supply reel motor speed is abnormally high, the error number flashes on the display.	Set the POWER switch to OFF and then to ON again.	STOP
E-67 T REEL ROTA TOO FAST	If the take-up reel motor speed is abnormally high, the error number flashes on the display.	Set the POWER switch to OFF and then to ON again.	STOP
E-69 T REEL TORQUE ERR	If excess torque being applied to the take-up reel motor is detected, the error number flashes on the display.	Set the POWER switch to OFF and then to ON again.	STOP
E-70 S REEL TORQUE ERR	If excess torque being applied to the supply reel motor is detected or an abnormal current flowing to the current detection resistor is detected, this error number flashes on the display.	Set the POWER switch to OFF and then to ON again.	STOP
E-71 CAP TENSION ERROR	If abnormal tension at the supply side is detected in the capstan mode, the error number flashes on the display.	Set the POWER switch to OFF and then to ON again.	STOP
E-72 REEL TENSION ERROR	If abnormal tension at the supply side is detected in the reel mode, the error number flashes on the display.	Set the POWER switch to OFF and then to ON again.	STOP
E-73 REEL DIR UNMATCH	If the take-up reel motor has rotated in the reverse direction, this error number flashes on the display.	Set the POWER switch to OFF and then to ON again.	STOP
E-74 DRUM TORQUE ERROR	If excess torque being applied to the cylinder motor is detected, this error number flashes on the display.	Set the POWER switch to OFF and then to ON again.	STOP
E-78 M-IF COMM ERROR	If a problem has been encountered in communication between the servo microcomputer and mechanism relay board, this error number flashes on the display.	Set the POWER switch to OFF and then to ON again.	STOP

Note:

Consult your dealer if the error message is still displayed even after restarting the unit.

Specifications

GENERAL

Power supply: AC 100 - 240 V, 50 / 60 Hz
Power consumption: 52 W

 indicates safety information.

Operating ambient temperature:

5 °C to 40 °C (41 °F to 104 °F)

Operating ambient humidity:

10 % to 80 % (no condensation)

Weight:

6.8 kg (14.99 lb)

Dimensions:

214 (W) x 132 (H) x 434 (D) mm
(8 7/16 x 5 3/16 x 17 3/32 inches)
(excluding support legs and connectors)

Recording format:

DVCPRO50/DVCPRO format selectable

Recording video signals:

For AJ-SD93P: 525i system

For AJ-SD93E: 625i system

Recording audio signals:

DVCPRO50 : 48 kHz, 16 bits, 4 channels

DVCPRO : 48 kHz, 16 bits, 2 channels

Recording tracks:

Digital video/audio

Helical track

Time code is recorded in the sub-code area.

Control (CTL): 1 track

Tape speed:

For AJ-SD93P

67.640 mm/sec. (DVCPRO50)

For AJ-SD93E

67.708 mm/sec. (DVCPRO50)

Recording times:

92 minutes (with AJ-5P92LP)

33 minutes (with AJ-5P33MP)

Tapes used:

Metal tapes

FF/REW time:

Less than 3 min. (with AJ-5P92LP)

Less than 2 min. (with AJ-5P33MP)

Digital slow:

-0.43x to +0.43x (DVCPRO, DVCPRO50)

Tape timer accuracy:

±1 frame (when using continuous CTL signal)

Servo lock time:

Less than 0.5 sec. (When the format for 2Fmode, standby ON, or setup menu No. 012 (SYS FORMAT) is the same as the format recorded to the tape)

VIDEO

■ Digital video

Sampling frequency:

Y:13.5 MHz; PB/PR: 6.75 MHz (DVCPRO50)

Quantizing:

8 bits

Video compression method:

DV-Based compression (SMPTE 314M)

Video compression rate:

DVCPRO50: 1/3.3

DVCPRO : 1/5

Error correction:

Reed-Solomon product code

Bit rate:

DVCPRO50: 50 Mbps

DVCPRO : 25 Mbps

■ Digital IN/Analog Component OUT

Video bandwidth (when using AJ-YA93P, AJ-YA94G options):

For AJ-SD93P

Y : 30 Hz to 5.5 MHz (±1 dB),
5.75 MHz (−2 dB)

PB/PR : 30 Hz to 2.5 MHz (±1 dB),
2.75 MHz (−2 dB)

For AJ-SD93E

Y : 25 Hz to 5.5 MHz (±1 dB),
5.75 MHz (−2 dB)

PB/PR : 25 Hz to 2.5 MHz (±1 dB),
2.75 MHz (−2 dB)

S/N ratio:

Better than 58 dB (Y)

K factor:

Less than 1 % (Y 2T)

Y/PB/PR delay:

Less than 10 nsec.

■ Video input signals

Analog component input (option: AJ-YA93P):

BNC x 3 (Y, PB, PR) (also used as VIDEO IN connectors)

For AJ-SD93P

Y : 1.0 V[p-p]

PB/PR : 0.486/0.7 V[p-p] selectable
(75 Ω, 75 % color bar, 7.5 % setup level)

For AJ-SD93E

Y : 1.0 V[p-p]

PB/PR : 0.7 V[p-p]

(75 Ω, 100 % color bar)

Analog composite input (option: AJ-YA93P):

BNC x 1

VIDEO: 1.0 V[p-p] (75 Ω)

Reference input (option: AJ-YA93P):

Analog composite, BNC x 2, loop-through, 75 Ω
ON/OFF automatically switched

SDI input (option: AJ-YA94G):

BNC x 1,

Compliant with SMPTE 259M-C/ITU-R BT. 656-4 standard

■ Video output signals

Analog component output (option: AJ-YA93P):

BNC x 3 (Y, PB, PR) (switchable with composite outputs)

For AJ-SD93P

Y : 1.0 V[p-p]

PB/PR : 0.486/0.7 V[p-p] selectable
(75 Ω, 75 % color bar, 7.5 % setup level)

For AJ-SD93E

Y : 1.0 V[p-p]

PB/PR : 0.7 V[p-p]

(75 Ω, 100 % color bar)

Analog composite output (option: AJ-YA93P):

BNC x 2, VIDEO1, VIDEO2

SDI output (option: AJ-YA94G):

BNC x 1,

Compliant with SMPTE 259M-C/ITU-R BT. 656-4 standard

Monitor output:

BNC x 1

■ Video adjustment ranges

Video output gain:

±3 dB

Video output chroma gain:

±3 dB

Video output HUE (chroma phase):

±30 °

Video output setup level (black level):

±14 IRE (±100 mV)

Video output sync phase:

±15 μsec.

Video output SC phase:

±180 °

Specifications (continued)

AUDIO

■ Digital Audio

Sampling frequency:

48 kHz (synchronized with video)

Quantizing:

16 bits

Frequency response:

20 Hz to 20 kHz ± 1.0 dB (at reference level)

Dynamic range:

More than 85 dB (1 kHz, emphasis OFF, "A" weighted)

Distortion:

Less than 0.1 % (1 kHz, emphasis OFF, reference level)

Crosstalk:

Less than -80 dB (1 kHz, between 2 channels)

Wow & flutter:

Below measurable limits

Headroom:

For AJ-SD93P: 20 dB

For AJ-SD93E: 18 dB

De-emphasis:

T1=50 μ sec., T2=15 μ sec. (ON/OFF automatically selected)

■ Audio input signals

Analog input (CH1, CH2, CH3, CH4) (option: AJ-YA93P):

XLR x 4, 600 Ω /high impedance selectable, +4/0/ -20 dBu selectable

SDI input (option: AJ-YA94G):

BNC x 1,

Compliant with SMPTE 259M-C/272M-A

/ITU-R BT. 656-4 standards

■ Audio output signals

Analog output (CH1, CH2, CH3, CH4) (option: AJ-YA93P):

XLR x 4, low impedance, +4/0/ -20 dBu selectable

SDI output (option: AJ-YA94G):

BNC x 1, 75 Ω ,

Compliant with SMPTE 259M-C/272M-A

/ITU-R BT. 656-4 standards

Monitor output:

PHONO x 2, 600 Ω , -8 dBV

Headphone output:

M3, stereo, 8 Ω , variable level

Other Input/Output Connectors

IEEE 1394 digital input/output:

IEEE 1394, 6 pins x 1,

400/200/100 Mbps selectable

Compliant with IEEE 1394-1995 standard

Compliant with IEC61883-Part 1, Part 2

Compliant with SMPTE 396M

AV/C Command Set supported

Time code input (option: AJ-YA93P):

BNC x 1, 0.5 to 8.0 V[p-p], 10 k Ω

Time code output (option: AJ-YA93P):

BNC x 1, low impedance, 2.0 ± 0.5 V[p-p]

RS-422A input/output (option: AJ-YA93P)

D-sub 9-pin, RS-422A interface

Weight and dimensions when shown are approximately.
Specifications are subject to change without notice.

Panasonic®

PANASONIC BROADCAST & TELEVISION SYSTEMS COMPANY
UNIT COMPANY OF MATSUSHITA ELECTRIC CORPORATION OF AMERICA

Executive Office:

One Panasonic Way 4E-7, Secaucus, NJ 07094 (201) 348-7000

EASTERN ZONE:

One Panasonic Way 4E-7, Secaucus, NJ 07094 (201) 348-7621

Southeast Region:

1225 Northbrook Parkway, Ste 1-160, Suwanee, GA 30024 (770) 338-6835

Central Region:

1707 N Randall Road E1-C-1, Elgin, IL 60123 (847) 468-5200

WESTERN ZONE:

3330 Cahuenga Blvd W., Los Angeles, CA 90068 (323) 436-3500

Government Marketing Department:

52 West Gude Drive, Rockville, MD 20850 (301) 738-3840

Broadcast PARTS INFORMATION & ORDERING:

9:00 a.m. – 5:00 p.m. (EST) (800) 334-4881/24 Hr. Fax (800) 334-4880

Emergency after hour parts orders (800) 334-4881

TECHNICAL SUPPORT:

Emergency 24 Hour Service (800) 222-0741

Panasonic Canada Inc.

5770 Ambler Drive, Mississauga, Ontario L4W 2T3 (905) 624-5010

Panasonic de Mexico S.A. de C.V.

Av angel Urraza Num. 1209 Col. de Valle 03100 Mexico, D.F. (52) 1 951 2127

Panasonic Sales Company

Division of Matsushita Electric of Puerto Rico Inc.

San Gabriel Industrial Park, 65th Infantry Ave., Km. 9.5, Carolina, Puerto Rico 00630 (787) 750-4300

Panasonic Broadcast Europe

Panasonic Marketing Europe GmbH

Hagenauer Str. 43, 65203 Wiesbaden-Biebrich Deutschland Tel: 49-611-235-481